

FEATURES

- Measurement of main electrical magnitudes.
- Suitable for three-phase or single-phase installations (3 lines).
- Power measurement (W or kW) and Energy with 3 registers.
- Currency and CO2 emissions estimation registers.
- KNX system clock synchronization is allowed.
- Up to 6 tariff cost-counters.
- Total data saving on KNX bus failure.
- Integrated KNX BCU.
- Dimensions 67 x 90 x 35mm (2 DIN units).
- DIN rail mounting (EN 50022), through pressure.
- Conformity with the CE directives (CE-mark on the right side).

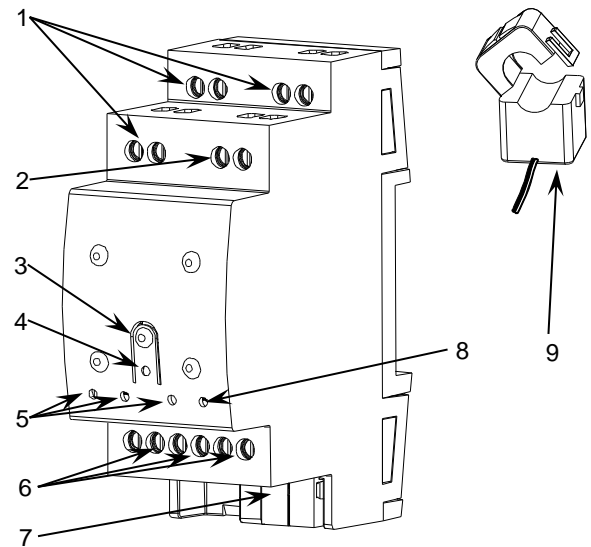

Figure 1. KES Plus

1. Phase/line (voltage)	2. Neutral (voltage)	3. Programming button	4. Programming LED	5. Phase/line status LED
6. Current transformer connection	7. KNX connector	8. Three-phase status LED	9. Current transformer*	

* Accessory not included

Programming button: short press to set programming mode. If this button is held while plugging the device into the KNX bus, it enters the safe mode.

Programming LED: programming mode indicator (red). When the device enters into safe mode, it blinks (red) every half second. During the start-up (reset or after KNX bus failure) and if the device is not in safe mode, it emits a red flash.

GENERAL SPECIFICATIONS

CONCEPT		DESCRIPTION		
Type of device		Electric operation control device		
KNX supply	Voltage (typical)	29VDC SELV		
	Voltage range	21...31VDC		
	Maximum consumption	Voltage	mA	mW
		29VDC (typical)	14.25	413.25
24VDC ⁽¹⁾	17.5	420		
Connection type		Typical bus connector TP1 for rigid cable 0.80mm Ø		
Voltage measurement range		110/230VAC @ 50/60Hz		
Operation temperature		0°C to +40°C		
Storage temperature		-20°C to +55°C		
Operation humidity		5 to 95% RH (no condensation)		
Storage humidity		5 to 95% RH (no condensation)		
Complementary characteristics		Class B		
Protection class		II		
Operation type		Continuous operation		
Device action type		Type 1		
Electrical stress period		Long		
Degree of protection		IP20, clean environment		
Installation		Independent device to be mounted inside electrical panels with DIN rail (EN 50022)		
Minimum clearances		Not required		
Response on KNX bus failure		Data saving according to parameterization		
Response on KNX bus restart		Data recovery according to parameterization		
Operation indicator		The programming LED indicates programming mode (red). Phase and three-phase status LEDs indicate the presence of consumption (yellow blinking) or generation (green blinking). The switch-on time during the blinking is proportional to the power that is flowing.		
Weight		101g		
PCB CTI index		175V		
Housing material		PC FR V0 halogen free		

⁽¹⁾ Maximum consumption in the worst case scenario (KNX Fan-In model)

ELECTRICAL SYSTEM SPECIFICATIONS AND CONNECTIONS	
CONCEPT	DESCRIPTION
Number of phases or lines	3
Voltage measurement range	110/230VAC @ 50/60Hz
Current measurement range	0.03 to 120A
Current measurement method	Electromagnetic induction
Connection method	Screw terminal block
Cable cross-section	0.5mm ² to 2.5mm ² (26-12 AWG)
Zennio current transformer (References) ⁽¹⁾	ZN1AC-CST60 (Zennio accessory) ZN1AC-CST120 (Zennio accessory)
Transformer ratio (loops number) ⁽¹⁾	Np:Ns=1:3000
Accuracy ⁽²⁾	1%

⁽¹⁾ It is not allowed to modify the cable length of the current transformer (Neither cutting nor splicing are allowed)

⁽²⁾ Accuracy on active power with a power factor between 0.75 and 1 with Zennio current transformer.

CONNECTION DIAGRAM (Three-phase system)

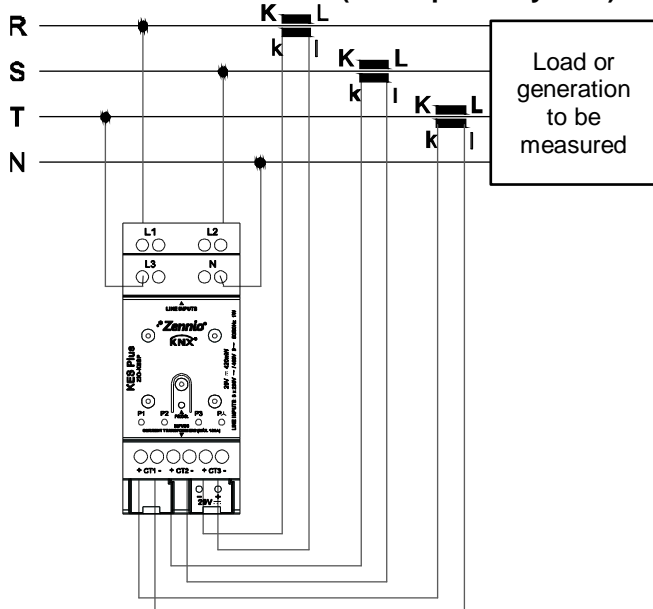

CONNECTION DIAGRAM (Single-phase system)

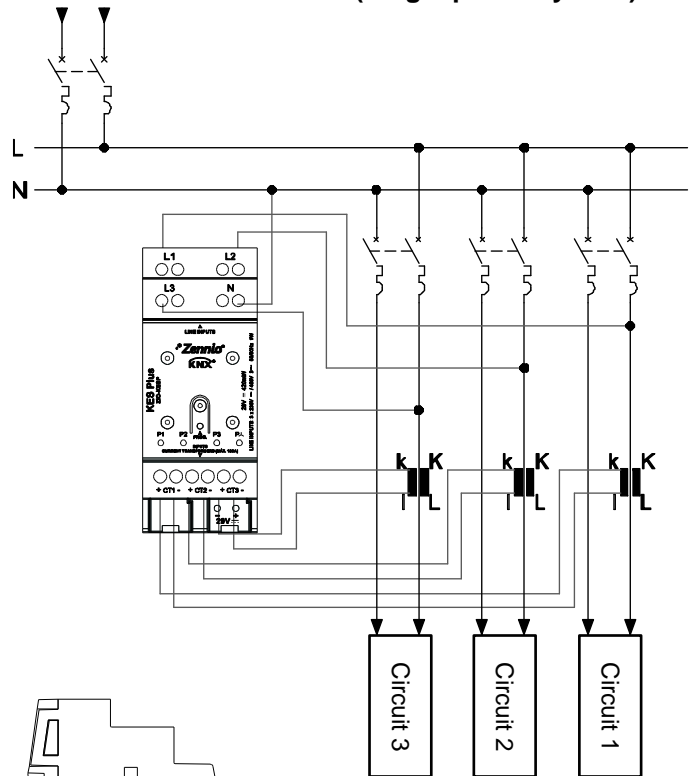

Attaching KES Plus to DIN rail:

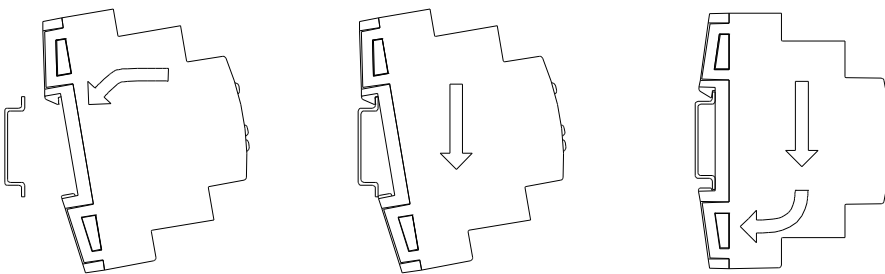

Removing KES Plus from DIN rail:

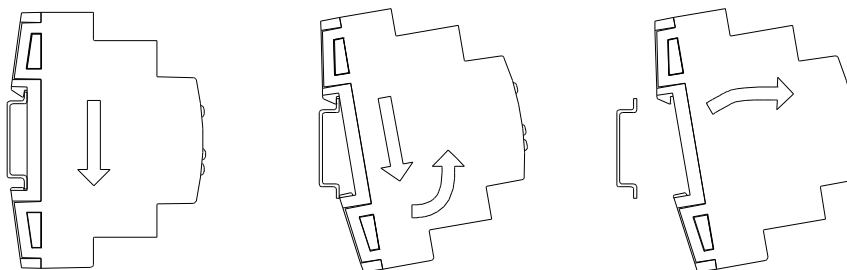

Current transformer detail (bottom part)

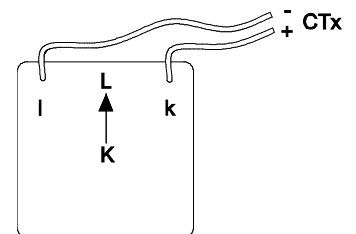

SAFETY INSTRUCTIONS

- Installation should only be performed by qualified professionals according to the laws and regulations applicable in each country.
- Do not connect the mains voltage nor any other external voltage to any point of the KNX bus; it would represent a risk for the entire KNX system. The facility must have enough insulation between the mains (or auxiliary) voltage and the KNX bus or the wires of other accessories, in case of being installed.
- The facility must be equipped with a device that ensures the omnipolar sectioning. Installation of a 10A mini-circuit-breaker is recommended. To prevent accidents, it must remain open in case of manipulation of the device.
- Once the device is installed (in the panel or box), it must not be accessible from outside.
- Keep the device away from water and do not cover it with clothes, paper or any other material while in use.
- The WEEE logo means that this device contains electronic parts and it must be properly disposed of by following the instructions at <http://zennio.com/weee-regulation>.

