

KNX Modbus Gateway with 250 data points

KNX Modbus RTU Gateway 886

Operation and installation manual



(Art. # 5256)

Weinzierl Engineering GmbH
Achatz 3
DE-84508 Burgkirchen / Alz
GERMANY

Tel: +49 (0)8677 / 91 636 – 0
info@weinzierl.de
www.weinzierl.de

Content

1	Application	3
2	Installation and connection.....	3
2.1	KNX programming mode.....	4
2.2	Manual operation and status display.....	4
3	Reset to factory default settings.....	5
4	Wiring scheme	5
4.1	Pluggable screw terminals	5
4.2	Pin assignment	6
5	ETS database	7
5.1	Description.....	7
5.2	General settings.....	8
5.3	Modbus settings.....	9
5.4	Datapoints N – M	12
5.5	Channel function “DPT 01 – binary – 1 bit”.....	16
5.6	Channel function “DPT 03 – dimming – 4 bit”	20
5.7	Channel function “DPT 05 – percent – 1 byte”.....	24
5.8	Channel function “DPT 05 – configured – 1 byte”.....	25
5.9	Channel function “DPT 05 – unsigned – 1 byte”	32
5.10	Channel function “DPT 06 – signed – 1 byte”	33
5.11	Channel function “DPT 07 – configured – 2 bytes”	34
5.12	Channel function “DPT 07 – unsigned – 2 bytes”	41
5.13	Channel function “DPT 08 – signed – 2 bytes”	42
5.14	Channel Function “DPT 09 – float – 2 bytes”.....	43
5.15	Channel Function “DPT 14 – float – 4 bytes”	44
5.16	General information.....	48

1 Application

The KNX Modbus RTU Gateway 886 is a compact gateway between KNX TP and Modbus RTU with 250 free configurable channels.

The device enables an easy integration of Modbus devices that support the RTU protocol via RS-485 and can act as Modbus master or slave. The device can be used as a master for up to 25 slave devices.

The assignment between KNX objects and Modbus registers can be configured via parameters in the ETS. No additional software is required. The KNX Bus and Modbus have a galvanic isolation from each other.

Two push buttons and three LEDs enable a local operation and a visualization of the device status.

2 Installation and connection

The KNX Modbus RTU Gateway 886 is designed for installation on a DIN rail (35 mm) with a width of 1 unit (18 mm). An installation friendly design with pluggable screw terminals helps to reduce the cost of commissioning. It features the following controls and displays:

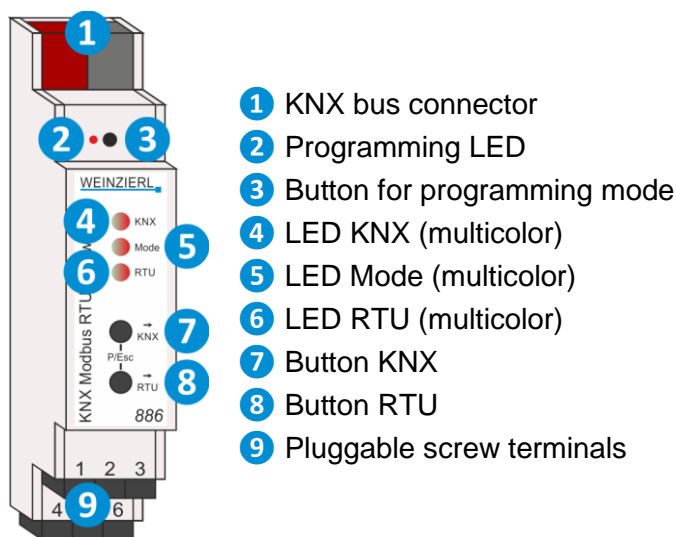

The device has galvanic isolation between Modbus and KNX. The Modbus side must be connected with 12...24 V $\overline{\text{=}}$. The unchoked output voltage from the KNX power supply must not be used for this purpose.



If the bus voltage is missing, the device is without function.

2.1 KNX programming mode

The KNX programming mode is activated/deactivated either by pressing the flushed KNX programming button **3** or by simultaneously pressing the buttons **7** and **8**. The operation of the programming mode at the front can be activated/deactivated in the ETS® with Prog. mode on device front.

When the programming mode is active, the programming LED **2** and the LED Mode **5** light up red.

2.2 Manual operation and status display

The LED KNX **4** lights up or flashes when KNX bus voltage is present.

The LED Mode **5** lights up or flashes when KNX bus voltage is present.

The LED RTU **6** lights up or flashes when supply voltage is present.

The synchronization of the KNX objects is triggered by pressing the button KNX **7** for a long time. This is indicated by the LED Mode **5** lighting up in orange.

Pressing the button RTU **8** for a long time triggers the synchronization of the Modbus registers. This is indicated by the LED Mode **5** lighting up in orange.

The LED KNX **4** is used to indicate the status of KNX communication. It flashes when sending and receiving telegrams.

The LED RTU **6** indicates the status of the Modbus communication. It flashes when sending and receiving telegrams.

Summary of the states of the LED Mode **5**:

LED Status	Meaning
LED lights green	The unit operates in normal operating mode.
LED lights red	The programming mode is active.
LED lights orange	The programming mode is not active. Synchronization is active.
LED flashes red	The programming mode is not active. Synchronization is not active. The device is not loaded correctly, e.g. after aborting a download.
LED flashes green	The device is currently loaded by the ETS.

3 Reset to factory default settings

It is possible to reset the device to the factory default settings:

- Disconnect the KNX Bus connector **1** from the device.
- Press the KNX programming button **3** and keep it pressed down.
- Reconnect the KNX Bus connector **1** to the device.
- Keep the KNX programming button **3** pressed for at least another 6 seconds.
- A short flashing of all LEDs (**2 4 5 6**) visualizes the successful reset of the device to factory default settings.

In the factory default settings, the device has the physical address 15.15.255 and no group addresses are connected.

4 Wiring scheme

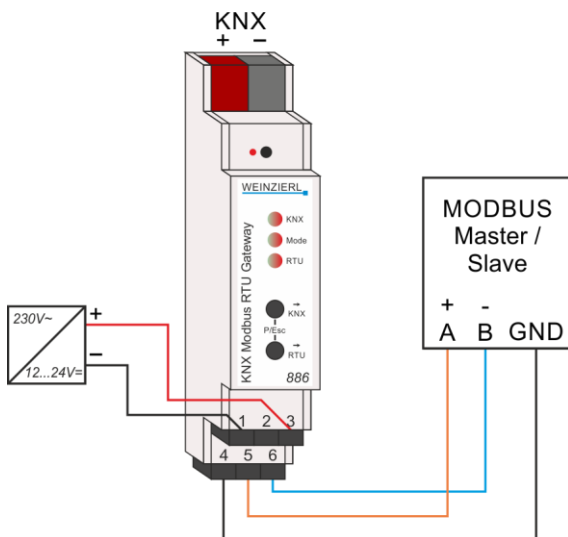

4.1 Pluggable screw terminals

The upper terminal is used to connect the supply voltage 12 ... 24 V₌, the lower terminal to connect the Modbus:

-	-	+
-	A	B

4.2 Pin assignment

Connection	Icon	Description
1	-	Ground connection for supply voltage
2	-	Ground connection for supply voltage
3	+	Positive connection for supply voltage 12 ... 24 V $\overline{=}$
4	-	Ground connection for Modbus (connected to connection 1 and connection 2)
5	A	Data line A (+) for Modbus
6	B	Data line B (-) for Modbus
KNX	+	Positive connection for KNX bus
KNX	-	Ground connection for KNX bus

The transmission line must be terminated at the last receiver of the Modbus transmission line with a 120 Ohm / 0.25 W resistor. This resistor must be inserted directly between the two signal lines before the input of the last device.

Only shielded and twisted cables should be used for Modbus.

5 ETS database

The ETS5 database (for ETS 5.7 or newer) can be downloaded from the product website of the KNX Modbus RTU Gateway 886 (www.weinzierl.de) or from the ETS online catalogue.

5.1 Description

1.1.1 KNX Modbus RTU Gateway 886 > Description	
Description	
General settings	KNX Modbus RTU Gateway 886 KNX Modbus Gateway with 250 datapoints
Modbus settings	
Datapoints 1 - 10	
Datapoints 11 - 20	The KNX Modbus RTU Gateway 886 is a compact Gateway between KNX TP and Modbus RTU with 250 freely configurable channels.
Datapoints 21 - 30	The device enables easy integration of Modbus devices that support the RTU protocol via RS-485 and can act as a Modbus master or slave. As Master the device can address up to 25 slave devices.
Datapoints 31 - 40	The assignment between KNX objects and Modbus registers can be configured via parameters in the ETS without an additional tool.
Datapoints 41 - 50	The gateway provides a galvanic isolation between KNX bus and Modbus.
Datapoints 51 - 60	Two buttons and three LEDs allow local operation and visualization of the device status.
Datapoints 61 - 70	
Datapoints 71 - 80	
Datapoints 81 - 90	
Datapoints 91 - 100	
Datapoints 101 - 110	
Datapoints 111 - 120	
Datapoints 121 - 130	
Datapoints 131 - 140	
Datapoints 141 - 150	
Datapoints 151 - 160	
Datapoints 161 - 170	
Datapoints 171 - 180	
	<p>Wiring scheme:</p> <p>Please consult device data sheet and manual for further information.</p> <p>Contact: Weinzierl Engineering GmbH Achatz 3 84508 Burgkirchen / Alz Germany www.weinzierl.de info@weinzierl.de</p>

The first page shows general information about the device.

5.2 General settings

1.1.1 KNX Modbus RTU Gateway 886 > General settings	
Description	Device name <input type="text" value="KNX Modbus RTU Gateway 886"/>
General settings	Send delay after bus power return <input type="text" value="5 s"/>
Modbus settings	Prog. mode on device front <input type="radio"/> Disabled <input checked="" type="radio"/> Enabled
Datapoints 1 - 10	Manual operation (sync) on device <input type="radio"/> Disabled <input checked="" type="radio"/> Enabled
Datapoints 11 - 20	Heartbeat <input type="radio"/> Disabled <input checked="" type="radio"/> Enabled
Datapoints 21 - 30	Cycle time <input type="text" value="5 min"/>
Datapoints 31 - 40	KNX settings
Datapoints 41 - 50	Telegram rate limitation <input type="radio"/> Disabled <input checked="" type="radio"/> Enabled
	Time telegram rate <input type="text" value="1.0 s"/>

Device name (30 characters)

Any arbitrary name can be assigned to the KNX Modbus RTU Gateway 886. The device name should be meaningful, e.g. "Living room ground floor". This helps the clarity of the ETS project.

Send delay after bus power return

The send delay of telegrams after the return of the bus voltage can be set via this parameter. In this case, telegrams from the device are sent to the KNX bus in a delayed manner by the set time. This reduces the bus load when the bus voltage returns. Other functions such as receiving telegrams are not affected by this parameter.

Prog. mode on device front

In addition to the normal programming button **3** the device allows activating the programming mode on the device front without opening the switchboard cover. The programming mode can be activated and deactivated via pressing simultaneously both buttons **7** and **8**.

This feature can be enabled and disabled via the parameter Prog. mode on device front. The recessed programming button **3** (next to the programming LED **2**) is always enabled and is not affected by this parameter.

Manual operation (sync) on device

This parameter is used to configure manual operation on the device. The manual operation can be activated or deactivated.

Manual operation enables synchronization of all channels in the direction to KNX (button KNX **7**) and in the direction to Modbus (button RTU **8**).

Direction KNX:

All datapoints of the channels configured as "Modbus to KNX" send their current value on the KNX bus.

Direction Modbus:

If the gateway is operating as Modbus master, all registers of the channels configured "KNX to Modbus" are written to Modbus again.

Synchronization can be cancelled by pressing the buttons **7** and **8** simultaneously.

Heartbeat

Cyclic sending of values to the KNX bus, to indicate that the device is operational. For the Cycle time values between 1 min and 24 h are selectable.

Group object	Type KNX	Size	Direction
GO 277 Heartbeat – Trigger	1.001	1 bit	To KNX

Telegram rate limitation

With this parameter the telegram rate limitation can be activated or deactivated.

Time telegram rate

If telegram rate limitation is activated, the time between the telegrams can be configured here. Times between 0.1 sec. and 1.0 sec. can be selected.



The telegram rate limitation only occurs when the bus load is increased.

5.3 Modbus settings

1.1.1 KNX Modbus RTU Gateway 886 > Modbus settings

Description	KNX Gateway	<input checked="" type="radio"/> Modbus master <input type="radio"/> Modbus slave
General settings	Slave address (common)	<input type="text" value="1"/>
Modbus settings	Baudrate	19200 bits/s
Datapoints 1 - 10	Parity	Even (1 stop bit)
Datapoints 11 - 20	Byte order	<input checked="" type="radio"/> MSB first <input type="radio"/> LSB first
Datapoints 21 - 30	Register address	<input checked="" type="radio"/> 0 based <input type="radio"/> 1 based
Datapoints 31 - 40	Request settings	
Datapoints 41 - 50	Time till next request	Minimal
Datapoints 51 - 60	Time till next cycle	Minimal
Datapoints 61 - 70	Multi read requests	<input checked="" type="radio"/> Disabled <input type="radio"/> Enabled
	Diagnostic settings	
	Diagnostic objects	<input checked="" type="radio"/> Disabled <input type="radio"/> Enabled

KNX Gateway

This parameter defines the role of the KNX gateway within the client/server architecture of the Modbus environment. Available are:

- Modbus master
- Modbus slave

Slave address (common)

Here the general slave address (0 ... 247) is set and used according to KNX Gateway configuration.

Modbus master:

The slave address of the Modbus communication partner is entered here. If several Slave devices are to be addressed, a specific slave address can be assigned per parameter page (e.g. datapoints 1-10).

Modbus slave:

The slave address of the KNX gateway is entered here.

Baudrate

Configures the baudrate of the Modbus communication. The following are available:

- 1200 bits/s
- 2400 bits/s
- 4800 bits/s
- 9600 bits/s
- 19200 bits/s
- 38400 bits/s
- 56000 bits/s
- 115200 bits/s

Parity

Here the Modbus frame is parameterized with regard to parity and stop bit. The following options are available:

- Even (1 stop bit)
- Odd (1 stop bit)
- None (2 stop bits)
- None (1 stop bit)

Byte order

Defines the order for the transmission of 2 byte values:

- MSB first (high byte is sent first)
- LSB first (low byte is sent first)

Register address

Here it is set on which address basis the register address is defined:

- 0 based
- 1 based

Time till next request *(only in Master mode)*

This parameter defines the minimum time for the next request. Used to slow down the master.

Time till next cycle *(only in Master Mode)*

This parameter defines the time after which a new request cycle has to begin. If the time is too short, the cycle will not be completed. This is indicated by the red flashing of the RTU LED **6**.

Multi read requests *(only in Master Mode)*

When this parameter is activated, Modbus registers which lie one after the other in the channels are combined in a multi-read request.



The slave address and the function code must be identical. The register address must be continuous, but repetitions may occur. A maximum of 16 channels can be combined.

Example:

Type Slave address: Common

Channel 1 – MB to KNX – Read holding register – Address 0

Channel 2 – MB to KNX – Read holding register – Address 1

Channel 3 – MB to KNX – Read holding register – Address 2

Channel 4 – MB to KNX – Read holding register – Address 2

Channel 5 – MB to KNX – Read holding register – Address 3

Channel 6 – MB to KNX – Read holding register – Address 4

Channel 7 – MB to KNX – Read holding register – Address 4

The result is a read-multi-holding-register request for addresses 0 – 4.

Diagnostic objects

Activated, objects for diagnostic are displayed and provide information about the communication with the respective slave device.

Modbus master:

If no response is received from the slave device, “No communication – On” is sent to the KNX bus via the diagnostic object.

Modbus slave:

If no request is received from the master within the time interval, “No communication – On” is sent to the KNX bus via the diagnostic object.

Group object	Type KNX	Size	Direction
GO 276 Diagnostic: Slave (common) – No communication	1.001	1 bit	To KNX

5.4 Datapoints N – M

1.1.1 KNX Modbus RTU Gateway 886 > Datapoints 1 - 10

Description	Slave address type	<input type="radio"/> Common <input checked="" type="radio"/> For this page
General settings	Slave address	1
Modbus settings	Slave description	
Datapoints 1 - 10	Channel 1	Datapoint type: Disabled
Datapoints 11 - 20	Channel 2	Datapoint type: Disabled
Datapoints 21 - 30	Channel 3	Datapoint type: Disabled
Datapoints 31 - 40	Channel 4	Datapoint type: Disabled
Datapoints 41 - 50	Channel 5	Datapoint type: Disabled
Datapoints 51 - 60	Channel 6	Datapoint type: Disabled
Datapoints 61 - 70	Channel 7	Datapoint type: Disabled
Datapoints 71 - 80	Channel 8	Datapoint type: Disabled
Datapoints 81 - 90	Channel 9	Datapoint type: Disabled
Datapoints 91 - 100	Channel 10	Datapoint type: Disabled

10 channels are combined per page.

Slave address type *(only in master mode)*

This parameter determines whether the general address or another slave address is to be used for the configured channels on this page.

Slave address *(only in master mode)*

Here the slave address (0 ... 247) of the channels of this page is set.

Slave description *(only in master mode)*

If the diagnostic is activated, the diagnostic object of this page can be named here.

Group object	Type KNX	Size	Direction
GO 251 Diagnostic: Slave (page 1) – No communication	1.001	1 bit	To KNX

Datapoint type

This parameter activates and defines the KNX interface and the function of this channel. The following options are available:

- Disabled
- DPT 01 – binary – 1 bit

Group object	Type KNX	Size	Direction
GO 1 Channel 1: ... – Switch – 1 bit	1.001	1 bit	...

- DPT 03 – dimming – 4 bits

Group object	Type KNX	Size	Direction
GO 1 Channel 1: ... – Dimming – 4 bits	3.007	4 bits	...

- DPT 05 – percent – 1 byte

Group object	Type KNX	Size	Direction
GO 1 Channel 1: ... – Percent – 1 byte	5.001	1 byte	...

- DPT 05 – configured – 1 byte

Group object	Type KNX	Size	Direction
GO 1 Channel 1: ... – Configured – 1 byte	5.010	1 byte	...

- DPT 05 – unsigned – 1 byte

Group object	Type KNX	Size	Direction
GO 1 Channel 1: ... – Unsigned – 1 byte	5.010	1 byte	...

- DPT 06 – signed – 1 byte

Group object	Type KNX	Size	Direction
GO 1 Channel 1: ... – Signed – 1 byte	6.010	1 byte	...

- DPT 07 – configured – 2 bytes

Group object	Type KNX	Size	Direction
GO 1 Channel 1: ... – Configured – 2 bytes	7.001	2 bytes	...

- DPT 07 – unsigned – 2 bytes

Group object	Type KNX	Size	Direction
GO 1 Channel 1: ... – Unsigned – 2 bytes	7.001	2 bytes	...

- DPT 08 – signed – 2 bytes

Group object	Type KNX	Size	Direction
GO 1 Channel 1: ... – Signed – 2 bytes	8.001	2 bytes	...

- DPT 09 – float – 2 bytes

Group object	Type KNX	Size	Direction
GO 1 Channel 1: ... – Float – 2 bytes	9.001	2 bytes	...

- DPT 14 – float – 4 bytes

Group object	Type KNX	Size	Direction
GO 1 Channel 1: ... – Float – 4 bytes	14.000	4 bytes	...

Description (30 characters)

Any name can be assigned to the channel. However, this should be unique and meaningful, which makes it easier to work with the associated group objects later, since the name assigned is displayed there as a description. If no name is assigned, the group objects are designated as “Channel N: ...”.

Direction

The KNX specific communication direction is set here:

- KNX to Modbus (*group object is input*)

Group object	Type KNX	Size	Direction
GO 1 Channel 1: Input – ...	Depending on DPT		From KNX

- Modbus to KNX (*group object is output*)

Group object	Type KNX	Size	Direction
GO 1 Channel 1: Output – ...	Depending on DPT		To KNX

Send condition

If the group object is defined as an output, the time at which the object sends the value to the KNX bus is configured here. The following options are available:

- Read only
Object sends only on read requests
- On change
Object sends on value change
- Cyclic
Object sends after cycle time
- Cyclic and on change
Object transmits after cycle time and on value change

Cycle time

The time for send condition cyclic.

Type

This parameter defines the function of the channel as well as the size of the Modbus register used.

Depending on the parameter **Datapoint type N** various channel functions are possible, which will be discussed in more detail in the following chapters.

For “Value in word register” it should be noted that the channel does not work in case of incorrect configuration.



The **Bit count** and **Offset** together must not be greater than 16.

The value must fit into **Bit count**, for example **Bit count** = 1 → “Value” = 0 or 1.

Function

The Modbus function code for this channel is configured here.

Different function codes can be configured depending on **KNX gateway** (Modbus master/slave), **Direction** and **Type**.

Word register:

Modbus Master | KNX to Modbus

- Write single holding register – 06
- Write multi holding registers – 16
(for “DPT 14” and “Double word register”)

Modbus Master | Modbus to KNX

- Read holding registers – 03
- Read input registers – 04

Modbus Slave | KNX to Modbus

- Read holding registers – 03
- Read input registers – 04

Modbus Slave | Modbus to KNX

- Write single/multi holding registers – 06, 16

Bit Register:

Modbus Master | KNX to Modbus

- Write single coil – 05

Modbus Master | Modbus to KNX

- Read coils – 01
- Read discrete inputs – 02

Modbus Slave | KNX to Modbus

- Read coils – 01
- Read discrete inputs – 02

Modbus Slave | Modbus to KNX

- Write single/multi coils – 05, 15

Address

Here the address of the Modbus register is configured. An address range from 0 ... 65535 is available.



If address 0 is configured with “1 based”, this is a static error which deactivates the channel function and is indicated by LED RTU **6** lighting up in red.

Polling interval (only in Master mode and for Modbus to KNX)

This defines the cyclic intervals of read requests for the respective register. The following options are available:

- Every cycle
- Every second cycle
- Every fourth cycle
- Every sixth cycle
- Every eighth cycle

5.5 Channel function “DPT 01 – binary – 1 bit”

Type

The following types are configurable:

- Bit register
1 bit (KNX) sets bit register (Modbus)
- Bit in word register
1 bit (KNX) sets 1 bit in word register (Modbus)
- Value in word register
1 bit (KNX) is mapped to value in word register (Modbus)

5.5.1 Type – Bit register

1.1.1 KNX Modbus RTU Gateway 886 > Datapoints 1 - 10	
Description	Slave address type <input checked="" type="radio"/> Common <input type="radio"/> For this page
General settings	Channel 1
Modbus settings	Datapoint type <input type="text" value="DPT 01 - binary - 1 bit"/>
Datapoints 1 - 10	Description <input type="text"/>
Datapoints 11 - 20	Direction <input checked="" type="radio"/> KNX to modbus <input type="radio"/> Modbus to KNX
Datapoints 21 - 30	Type <input type="text" value="Bit register"/>
Datapoints 31 - 40	Value inverted <input checked="" type="radio"/> No <input type="radio"/> Yes
Datapoints 41 - 50	Function <input type="text" value="Write single coil - 05"/>
	Address <input type="text" value="0"/>

Value inverted

If yes, the inverted value of the group object corresponds to the value of the bit register.

5.5.2 Type – Bit in word register

1.1.1 KNX Modbus RTU Gateway 886 > Datapoints 1 - 10	
Description	Slave address type <input checked="" type="radio"/> Common <input type="radio"/> For this page
General settings	Channel 1
Modbus settings	Datapoint type DPT 01 - binary - 1 bit
Datapoints 1 - 10	Description
Datapoints 11 - 20	Direction <input type="radio"/> KNX to modbus <input checked="" type="radio"/> Modbus to KNX
Datapoints 21 - 30	Send condition On change
Datapoints 31 - 40	Type Bit in word register
Datapoints 41 - 50	Position (register) Bit 00
Datapoints 51 - 60	Value inverted <input checked="" type="radio"/> No <input type="radio"/> Yes
Datapoints 61 - 70	Function <input checked="" type="radio"/> Read holding registers - 03 <input type="radio"/> Read input registers - 04
Datapoints 61 - 70	Address 0
Datapoints 71 - 80	Polling interval Every cycle

Position (register)

Defines the bit in the word register.

Value inverted

If yes, the inverted value of the group object corresponds to the value of the bit in the word register.

5.5.3 Type – Value in word register

Bit count

This parameter defines the size of the value in the word register (in bits).

Offset

This parameter defines the position of the value in the word register (offset from the right in bits).

5.5.3.1 Direction – KNX to Modbus

1.1.1 KNX Modbus RTU Gateway 886 > Datapoints 1 - 10	
Description	Slave address type <input checked="" type="radio"/> Common <input type="radio"/> For this page
General settings	Channel 1
Modbus settings	Datapoint type <input type="text" value="DPT 01 - binary - 1 bit"/>
Datapoints 1 - 10	Description <input type="text"/>
Datapoints 11 - 20	Direction <input checked="" type="radio"/> KNX to modbus <input type="radio"/> Modbus to KNX
Datapoints 21 - 30	Type <input type="text" value="Value in word register"/>
Datapoints 31 - 40	Bit count <input type="text" value="16 bit"/>
Datapoints 41 - 50	Offset <input type="text" value="00 bit"/>
Datapoints 51 - 60	Behaviour on receiving data 'ON' <input type="radio"/> No reaction <input checked="" type="radio"/> Set register value
Datapoints 61 - 70	Value <input type="text" value="1"/>
Datapoints 71 - 80	Behaviour on receiving data 'OFF' <input type="radio"/> No reaction <input checked="" type="radio"/> Set register value
Datapoints 81 - 90	Value <input type="text" value="0"/>
	Function <input type="text" value="Write single holding register - 06"/>
	Address <input type="text" value="0"/>

Behaviour on receiving data 'ON'

Here it can be configured whether a value is to be set in the register when an 'ON' telegram is received.

Value

The value that is set in the register when an 'ON' telegram is received.

Behaviour on receiving data 'OFF'

Here it can be configured whether a value is to be set in the register when an 'OFF' telegram is received.

Value

The value that is set in the register when an 'OFF' telegram is received.

5.5.3.2 Direction – Modbus to KNX

1.1.1 KNX Modbus RTU Gateway 886 > Datapoints 1 - 10	
Description	Slave address type <input checked="" type="radio"/> Common <input type="radio"/> For this page
General settings	Channel 1
Modbus settings	Datapoint type <input type="text" value="DPT 01 - binary - 1 bit"/>
Datapoints 1 - 10	Description <input type="text"/>
Datapoints 11 - 20	Direction <input type="radio"/> KNX to modbus <input checked="" type="radio"/> Modbus to KNX
Datapoints 21 - 30	Send condition <input type="text" value="On change"/>
Datapoints 31 - 40	Type <input type="text" value="Value in word register"/>
Datapoints 41 - 50	Bit count <input type="text" value="16 bit"/>
Datapoints 51 - 60	Offset <input type="text" value="00 bit"/>
Datapoints 61 - 70	Value <input type="text" value="1"/>
Datapoints 71 - 80	Behaviour on value higher <input type="text" value="Send 'OFF'"/>
Datapoints 81 - 90	Behaviour on value match <input type="text" value="Send 'ON'"/>
Datapoints 91 - 100	Behaviour on value lower <input type="text" value="Send 'OFF'"/>
Datapoints 101 - 110	Function <input checked="" type="radio"/> Read holding registers - 03 <input type="radio"/> Read input registers - 04
	Address <input type="text" value="0"/>
	Polling interval <input type="text" value="Every cycle"/>

Value

The value for which the register is checked. Depends on **Bit count** and **Offset**.

Behaviour on value higher

This parameter defines the behaviour of the group object if the register value is greater than the parameterized value. The following options are available:

- No reaction
- Send 'ON'
- Send 'OFF'

Behaviour on value match

This parameter defines the behaviour of the group object in case the register value corresponds to the parameterized value. The following options are available:

- No reaction
- Send 'ON'
- Send 'OFF'

Behaviour on value lower

This parameter defines the behaviour of the group object in case the register value is smaller than the parameterized value. The following options are available:

- No reaction
- Send 'ON'
- Send 'OFF'

5.6 Channel function “DPT 03 – dimming – 4 bit”

Type

The following types are configurable:

- Bit register
4 bit dimming command (KNX) sets bit register (Modbus)
- Value in word register
4 bit dimming command (KNX) is mapped to value in word register (Modbus)

5.6.1 Type – Bit Register

5.6.1.1 Direction – KNX to Modbus

1.1.1 KNX Modbus RTU Gateway 886 > Datapoints 1 - 10	
Description	Slave address type <input checked="" type="radio"/> Common <input type="radio"/> For this page
General settings	Channel 1
Modbus settings	Datapoint type DPT 03 - dimming - 4 bits
Datapoints 1 - 10	Description <input type="text"/>
Datapoints 11 - 20	Direction <input checked="" type="radio"/> KNX to modbus <input type="radio"/> Modbus to KNX
Datapoints 21 - 30	Type <input checked="" type="radio"/> Bit register <input type="radio"/> Value in word register
Datapoints 31 - 40	Behaviour on receiving data 'DIM UP' Register '1'
Datapoints 41 - 50	Behaviour on receiving data 'DIM DOWN' No reaction
Datapoints 51 - 60	Behaviour on receiving data 'DIM STOP' Register '0'
Datapoints 61 - 70	Function Write single coil - 05
	Address 0

Behaviour on receiving data ‘DIM UP’

This parameter defines the behaviour of the bit register in case a ‘DIM UP’ telegram has been received at the group object. The following options are available:

- No reaction
- Register ‘1’
- Register ‘0’

Behaviour on receiving data ‘DIM DOWN’

This parameter defines the behaviour of the bit register in case a ‘DIM DOWN’ telegram was received at the group object. The following options are available:

- No reaction
- Register ‘1’
- Register ‘0’

Behaviour on receiving data 'DIM STOP'

This parameter defines the behaviour of the bit register in case a 'DIM STOP' telegram has been received at the group object. The following options are available:

- No reaction
- Register '1'
- Register '0'

5.6.1.2 Direction – Modbus to KNX

1.1.1 KNX Modbus RTU Gateway 886 > Datapoints 1 - 10	
Description	Slave address type <input checked="" type="radio"/> Common <input type="radio"/> For this page
General settings	Channel 1
Modbus settings	Datapoint type <input type="text" value="DPT 03 - dimming - 4 bits"/>
Datapoints 1 - 10	Description <input type="text"/>
Datapoints 11 - 20	Direction <input type="radio"/> KNX to modbus <input checked="" type="radio"/> Modbus to KNX
Datapoints 21 - 30	Send condition <input type="text" value="On change"/>
Datapoints 31 - 40	Type <input checked="" type="radio"/> Bit register <input type="radio"/> Value in word register
Datapoints 41 - 50	Behaviour on register '1' <input type="text" value="Send 'DIM UP'"/>
Datapoints 51 - 60	Behaviour on register '0' <input type="text" value="Send 'DIM STOP'"/>
Datapoints 61 - 70	Function <input checked="" type="radio"/> Read coils - 01 <input type="radio"/> Read discrete inputs - 02
Datapoints 71 - 80	Address <input type="text" value="0"/>
	Polling interval <input type="text" value="Every cycle"/>

Behaviour on register '1'

This parameter defines the behaviour of the group object in case the register value corresponds to the parameterized value. The following options are available:

- No reaction
- Send 'DIM UP'
- Send 'DIM DOWN'
- Send 'DIM STOP'

Behaviour on register '0'

This parameter defines the behaviour of the group object in case the register value corresponds to the parameterized value. The following options are available:

- No reaction
- Send 'DIM UP'
- Send 'DIM DOWN'
- Send 'DIM STOP'

5.6.2 Type – Value in word register

Bit count

This parameter defines the size of the value in the word register (in bits).

Offset

This parameter defines the position of the value in the word register (offset from the right in bits).

5.6.2.1 Direction – KNX to Modbus

1.1.1 KNX Modbus RTU Gateway 886 > Datapoints 1 - 10	
Description	Slave address type <input checked="" type="radio"/> Common <input type="radio"/> For this page
General settings	Channel 1
Modbus settings	Datapoint type <input type="text" value="DPT 03 - dimming - 4 bits"/>
Datapoints 1 - 10	Description <input type="text"/>
Datapoints 11 - 20	Direction <input checked="" type="radio"/> KNX to modbus <input type="radio"/> Modbus to KNX
Datapoints 21 - 30	Type <input type="radio"/> Bit register <input checked="" type="radio"/> Value in word register
Datapoints 31 - 40	Bit count <input type="text" value="16 bit"/>
Datapoints 41 - 50	Offset <input type="text" value="00 bit"/>
Datapoints 51 - 60	Behaviour on receiving data 'DIM UP' <input type="radio"/> No reaction <input checked="" type="radio"/> Set register value
Datapoints 61 - 70	Value <input type="text" value="1"/>
Datapoints 71 - 80	Behaviour on receiving data 'DIM DOWN' <input checked="" type="radio"/> No reaction <input type="radio"/> Set register value
Datapoints 81 - 90	Value <input type="text" value="0"/>
Datapoints 91 - 100	Behaviour on receiving data 'DIM STOP' <input type="radio"/> No reaction <input checked="" type="radio"/> Set register value
	Value <input type="text" value="0"/>
	Function <input type="text" value="Write single holding register - 06"/>
	Address <input type="text" value="0"/>

Behaviour on receiving data 'DIM UP'

Here it can be parameterized whether a value is to be set in the register when a 'DIM OPEN' telegram is received.

Value

The value that is set in the register when a 'DIM OPEN' telegram is received.

Behaviour on receiving data 'DIM DOWN'

Here it can be parameterized whether a value is to be set in the register when a 'DIM DOWN' telegram is received.

Value

The value that is set in the register when a 'DIMM DOWN' telegram is received.

Behaviour on receiving data 'DIM STOP'

Here it can be parameterized whether a value is to be set in the register when a 'DIM STOP' telegram is received.

Value

The value that is set in the register when a 'DIM STOP' telegram is received.

5.6.2.2 Direction – Modbus to KNX

1.1.1 KNX Modbus RTU Gateway 886 > Datapoints 1 - 10	
Description	Slave address type <input checked="" type="radio"/> Common <input type="radio"/> For this page
General settings	Channel 1
Modbus settings	Datapoint type <input type="text" value="DPT 03 - dimming - 4 bits"/>
Datapoints 1 - 10	Description <input type="text"/>
Datapoints 11 - 20	Direction <input type="radio"/> KNX to modbus <input checked="" type="radio"/> Modbus to KNX
Datapoints 21 - 30	Send condition <input type="text" value="On change"/>
Datapoints 31 - 40	Type <input type="radio"/> Bit register <input checked="" type="radio"/> Value in word register
Datapoints 41 - 50	Bit count <input type="text" value="16 bit"/>
Datapoints 51 - 60	Offset <input type="text" value="00 bit"/>
Datapoints 61 - 70	Value <input type="text" value="1"/>
Datapoints 71 - 80	Behaviour on value higher <input type="text" value="Send 'DIM STOP'"/>
Datapoints 81 - 90	Behaviour on value match <input type="text" value="Send 'DIM UP'"/>
Datapoints 91 - 100	Behaviour on value lower <input type="text" value="Send 'DIM STOP'"/>
Datapoints 101 - 110	Function <input checked="" type="radio"/> Read holding registers - 03 <input type="radio"/> Read input registers - 04
	Address <input type="text" value="0"/>
	Polling interval <input type="text" value="Every cycle"/>

Behaviour on value higher

This parameter defines the behaviour of the group object if the register value is greater than the parameterized value. The following options are available:

- No reaction
- Send 'DIM UP'
- Send 'DIM DOWN'
- Send 'DIM STOP'

Behaviour on value match

This parameter defines the behaviour of the group object in case the register value corresponds to the parameterized value. The following options are available:

- No reaction
- Send 'DIM UP'
- Send 'DIM DOWN'
- Send 'DIM STOP'

Behaviour on value lower

This parameter defines the behaviour of the group object in case the register value is smaller than the parameterized value. The following options are available:

- No reaction
- Send 'DIM UP'
- Send 'DIM DOWN'
- Send 'DIM STOP'

5.7 Channel function “DPT 05 – percent – 1 byte”

Type

The following type is configured:

- Word register
 - 1 byte percent value (KNX) is mapped to value in word register (Modbus)

5.7.1 Type – Word register

1.1.1 KNX Modbus RTU Gateway 886 > Datapoints 1 - 10	
Description	Slave address type <input checked="" type="radio"/> Common <input type="radio"/> For this page
General settings	Channel 1
Modbus settings	Datapoint type DPT 05 - percent - 1 byte
Datapoints 1 - 10	Description <input type="text"/>
Datapoints 11 - 20	Direction <input checked="" type="radio"/> KNX to modbus <input type="radio"/> Modbus to KNX
Datapoints 21 - 30	Type Word register
Datapoints 31 - 40	Position (register) Low byte
Datapoints 41 - 50	Value minimum (register) <input style="width: 50px;" type="text" value="0"/>
Datapoints 51 - 60	Value maximum (register) <input style="width: 50px;" type="text" value="255"/>
Datapoints 61 - 70	Value minimum (KNX) <input style="width: 50px;" type="text" value="0"/>
Datapoints 71 - 80	Value maximum (KNX) <input style="width: 50px;" type="text" value="100"/>
	Function Write single holding register - 06
	Address <input style="width: 50px;" type="text" value="0"/>

Position (register)

This parameter defines the area of the word register that is mapped. The following areas are available:

- Low byte
- High byte
- High/Low byte

Value minimum (register)

Register value which corresponds to **Value minimum (KNX)**.

Value maximum (register)

Register value which corresponds to **Value maximum (KNX)**.

Value minimum (KNX)

KNX value which corresponds to **Value minimum (register)**.

Value maximum (KNX)

KNX value, which corresponds to **Value maximum (register)**.



*The conversion is always transferred to the entire register area.
Value minimum/maximum (register) defines no limits.*

5.8 Channel function “DPT 05 – configured – 1 byte”

Type

The following types are configurable:

- Bit register
1 byte configured value (KNX) sets bit register (Modbus)
- Bit in word register
1 byte configured value (KNX) sets 1 bit in word register (Modbus)
- Value in word register
1 byte configured value (KNX) is mapped to value in word register (Modbus)

5.8.1 Type – Bit register

5.8.1.1 Direction – KNX to Modbus

1.1.1 KNX Modbus RTU Gateway 886 > Datapoints 1 - 10	
Description	Slave address type <input checked="" type="radio"/> Common <input type="radio"/> For this page
General settings	Channel 1
Modbus settings	Datapoint type ▼ DPT 05 - configured - 1 byte
Datapoints 1 - 10	Description <input type="text"/>
Datapoints 11 - 20	Direction <input checked="" type="radio"/> KNX to modbus <input type="radio"/> Modbus to KNX
Datapoints 21 - 30	Type ▼ Bit register
Datapoints 31 - 40	Value (object) ▲▼ 255
Datapoints 41 - 50	Behaviour on value higher ▼ Register '0'
Datapoints 51 - 60	Behaviour on value match ▼ Register '1'
Datapoints 61 - 70	Behaviour on value lower ▼ Register '0'
	Function Write single coil - 05
	Address ▲▼ 0

Value (object)

This parameter defines the value for which the group object (KNX) is checked.

Behaviour on value higher

This parameter defines the behaviour of the bit register in case the received value (KNX) is greater than the parameterized value. The following options are available:

- No reaction
- Register '1'
- Register '0'

Behaviour on value match

This parameter defines the behaviour of the bit register in case the received value (KNX) corresponds to the parameterized value. The following options are available:

- No reaction
- Register '1'
- Register '0'

Behaviour on value lower

This parameter defines the behaviour of the bit register in case the received value (KNX) is smaller than the parameterized value. The following options are available:

- No reaction
- Register '1'
- Register '0'

5.8.1.2 Direction – Modbus to KNX

1.1.1 KNX Modbus RTU Gateway 886 > Datapoints 1 - 10	
Description	Slave address type <input checked="" type="radio"/> Common <input type="radio"/> For this page
General settings	Channel 1
Modbus settings	Datapoint type <input type="text" value="DPT 05 - configured - 1 byte"/>
Datapoints 1 - 10	Description <input type="text"/>
Datapoints 11 - 20	Direction <input type="radio"/> KNX to modbus <input checked="" type="radio"/> Modbus to KNX
Datapoints 21 - 30	Send condition <input type="text" value="On change"/>
Datapoints 31 - 40	Type <input type="text" value="Bit register"/>
Datapoints 41 - 50	Behaviour on register '1' <input type="radio"/> No reaction <input checked="" type="radio"/> Send value
Datapoints 51 - 60	Value (object) <input type="text" value="255"/>
Datapoints 61 - 70	Behaviour on register '0' <input type="radio"/> No reaction <input checked="" type="radio"/> Send value
Datapoints 71 - 80	Value (object) <input type="text" value="0"/>
Datapoints 81 - 90	Function <input checked="" type="radio"/> Read coils - 01 <input type="radio"/> Read discrete inputs - 02
	Address <input type="text" value="0"/>
	Polling interval <input type="text" value="Every cycle"/>

Behaviour on register '1'

This parameter defines the behaviour of the group object in case the register is set. The following options are available:

- No reaction
- Send value

Value (object)

The value that is sent to KNX when the register is set.

Behaviour on register '0'

This parameter defines the behaviour of the group object in case the register is not set. The following options are available:

- No reaction
- Send value

Value (object)

The value that is sent to KNX when the register is not set.

5.8.2 Type – Bit in word register

5.8.2.1 Direction – KNX to Modbus

1.1.1 KNX Modbus RTU Gateway 886 > Datapoints 1 - 10	
Description	Slave address type <input checked="" type="radio"/> Common <input type="radio"/> For this page
General settings	Channel 1
Modbus settings	Datapoint type: DPT 05 - configured - 1 byte
Datapoints 1 - 10	Description
Datapoints 11 - 20	Direction: <input checked="" type="radio"/> KNX to modbus <input type="radio"/> Modbus to KNX
Datapoints 21 - 30	Type: Bit in word register
Datapoints 31 - 40	Value (object): 255
Datapoints 41 - 50	Position (register): Bit 00
Datapoints 51 - 60	Behaviour on value higher: Register '0'
Datapoints 61 - 70	Behaviour on value match: Register '1'
Datapoints 71 - 80	Behaviour on value lower: Register '0'
	Function: Write single holding register - 06
	Address: 0

Value (object)

This parameter defines the value for which the group object (KNX) is checked.

Position (register)

Defines the bit in the word register.

Behaviour on value higher

This parameter defines the behaviour of the bit in the word register in case the received value (KNX) is greater than the parameterized value. The following options are available:

- No reaction
- Register '1'
- Register '0'

Behaviour on value match

This parameter defines the behaviour of the bit in the word register in case the received value (KNX) corresponds to the parameterized value. The following options are available:

- No reaction
- Register '1'
- Register '0'

Behaviour on value lower

This parameter defines the behaviour of the bit in the word register in case the received value (KNX) is smaller than the parameterized value. The following options are available:

- No reaction
- Register '1'
- Register '0'

5.8.2.2 Direction – Modbus to KNX

1.1.1 KNX Modbus RTU Gateway 886 > Datapoints 1 - 10	
Description	Slave address type <input checked="" type="radio"/> Common <input type="radio"/> For this page
General settings	Channel 1
Modbus settings	Datapoint type <input type="text" value="DPT 05 - configured - 1 byte"/>
Datapoints 1 - 10	Description <input type="text"/>
Datapoints 11 - 20	Direction <input type="radio"/> KNX to modbus <input checked="" type="radio"/> Modbus to KNX
Datapoints 21 - 30	Send condition <input type="text" value="On change"/>
Datapoints 31 - 40	Type <input type="text" value="Bit in word register"/>
Datapoints 41 - 50	Position (register) <input type="text" value="Bit 00"/>
Datapoints 51 - 60	Behaviour on register '1' <input type="radio"/> No reaction <input checked="" type="radio"/> Send value
Datapoints 61 - 70	Value (object) <input type="text" value="255"/>
Datapoints 71 - 80	Behaviour on register '0' <input type="radio"/> No reaction <input checked="" type="radio"/> Send value
Datapoints 81 - 90	Value (object) <input type="text" value="0"/>
Datapoints 91 - 100	Function <input checked="" type="radio"/> Read holding registers - 03 <input type="radio"/> Read input registers - 04
	Address <input type="text" value="0"/>
	Polling interval <input type="text" value="Every cycle"/>

Position (register)

Defines the bit in the word register.

Behaviour on register '1'

This parameter defines the behaviour of the group object in case the bit in the word register is set. The following options are available:

- No reaction
- Send value

Value (object)

The value that is sent to KNX when the bit in the word register is set.

Behaviour on register '0'

This parameter defines the behaviour of the group object in case the bit in the word register is not set. The following options are available:

- No reaction
- Send value

Value (object)

The value which is sent to KNX if the bit in the word register is not set.

5.8.3 Type – Value in word register

Bit count

This parameter defines the size of the value in the word register (in bits).

Offset

This parameter defines the position of the value in the word register (offset from the right in bits).

5.8.3.1 Direction – KNX to Modbus

1.1.1 KNX Modbus RTU Gateway 886 > Datapoints 1 - 10	
Description	Slave address type <input checked="" type="radio"/> Common <input type="radio"/> For this page
General settings	Channel 1
Modbus settings	Datapoint type DPT 05 - configured - 1 byte
Datapoints 1 - 10	Description
Datapoints 11 - 20	Direction <input checked="" type="radio"/> KNX to modbus <input type="radio"/> Modbus to KNX
Datapoints 21 - 30	Type Value in word register
Datapoints 31 - 40	Value (object) 255
Datapoints 41 - 50	Bit count 16 bit
Datapoints 51 - 60	Offset 00 bit
Datapoints 61 - 70	Behaviour on value higher <input type="radio"/> No reaction <input checked="" type="radio"/> Set register value
Datapoints 71 - 80	Value (register) 0
Datapoints 81 - 90	Behaviour on value match <input type="radio"/> No reaction <input checked="" type="radio"/> Set register value
Datapoints 91 - 100	Value (register) 1
Datapoints 101 - 110	Behaviour on value lower <input type="radio"/> No reaction <input checked="" type="radio"/> Set register value
Datapoints 111 - 120	Value (register) 0
	Function Write single holding register - 06
	Address 0

Value (object)

This parameter defines the value for which the group object (KNX) is checked.

Behaviour on value higher

This parameter defines the behaviour of the word register in case the received value (KNX) is greater than the parameterized value. The following options are available:

- No reaction
- Set value in register

Value (register)

The value that is set in the word register.

Behaviour on value match

This parameter defines the behaviour of the word register in case the received value (KNX) corresponds to the parameterized value. The following options are available:

- No reaction
- Set value in register

Value (register)

The value that is set in the word register.

Behaviour on value lower

This parameter defines the behaviour of the word register in case the received value (KNX) is smaller than the parameterized value. The following options are available:

- No reaction
- Set value in register

Value (register)

The value that is set in the word register.

5.8.3.2 Direction – Modbus to KNX

1.1.1 KNX Modbus RTU Gateway 886 > Datapoints 1 - 10	
Description	Slave address type <input checked="" type="radio"/> Common <input type="radio"/> For this page
General settings	Channel 1
Modbus settings	Datapoint type DPT 05 - configured - 1 byte
Datapoints 1 - 10	Description <input type="text"/>
Datapoints 11 - 20	Direction <input type="radio"/> KNX to modbus <input checked="" type="radio"/> Modbus to KNX
Datapoints 21 - 30	Send condition On change
Datapoints 31 - 40	Type Value in word register
Datapoints 41 - 50	Bit count 16 bit
Datapoints 51 - 60	Offset 00 bit
Datapoints 61 - 70	Value (register) 1
Datapoints 71 - 80	Behaviour on value higher <input type="radio"/> No reaction <input checked="" type="radio"/> Send value
Datapoints 81 - 90	Value (object) 0
Datapoints 91 - 100	Behaviour on value match <input type="radio"/> No reaction <input checked="" type="radio"/> Send value
Datapoints 101 - 110	Value (object) 255
Datapoints 111 - 120	Behaviour on value lower <input type="radio"/> No reaction <input checked="" type="radio"/> Send value
Datapoints 121 - 130	Value (object) 0
Datapoints 131 - 140	Function <input checked="" type="radio"/> Read holding registers - 03 <input type="radio"/> Read input registers - 04
	Address 0
	Polling interval Every cycle

Value (register)

This parameter defines the value for which the word register is checked.

Behaviour on value higher

This parameter defines the behaviour of the group object (KNX) in the event that the register value is greater than the parameterized value. The following options are available:

- No reaction
- Send value

Value (object)

The value that is sent via the group object (KNX).

Behaviour on value match

This parameter defines the behaviour of the group object (KNX) in the event that the register value corresponds to the parameterized value. The following options are available:

- No reaction
- Send value

Value (object)

The value that is sent via the group object (KNX).

Behaviour on value lower

This parameter defines the behaviour of the group object (KNX) in the event that the register value is smaller than the parameterized value. The following options are available:

- No reaction
- Send value

Value (object)

The value that is sent via the group object (KNX).

5.9 Channel function “DPT 05 – unsigned – 1 byte”

Type

The following type is configured:

- Word register
 - 1 byte value unsigned (KNX) is written/read to/from area in word register (Modbus)

5.9.1 Type – Word register

1.1.1 KNX Modbus RTU Gateway 886 > Datapoints 1 - 10	
Description	Slave address type <input checked="" type="radio"/> Common <input type="radio"/> For this page
General settings	Channel 1
Modbus settings	Datapoint type DPT 05 - unsigned - 1 byte ▾
Datapoints 1 - 10	Description <input type="text"/>
Datapoints 11 - 20	Direction <input checked="" type="radio"/> KNX to modbus <input type="radio"/> Modbus to KNX
Datapoints 21 - 30	Type Word register
Datapoints 31 - 40	Position (register) Configured ▾
Datapoints 41 - 50	Bit count 08 bit ▾
Datapoints 51 - 60	Offset 00 bit ▾
	Function Write single holding register - 06
	Address 0 ▾

Position (register)

This parameter defines the area of the word register which is read/written. The following areas are available:

- Low byte
- High byte
- Configured

Bit count (only for configured)

This parameter defines the size of the area in the word register (in bits).

Offset (only for configured)

This parameter defines the position of the area in the word register (offset from the right in bits).



The **Bit count** and **Offset** together must not be greater than 16.
The value must fit into **Bit count**, for example **Bit count** = 1 → “Value” = 0 or 1.

5.10 Channel function “DPT 06 – signed – 1 byte”

Type

The following type is configured:

- Word register
1 byte value signed (KNX) is written/read to/from area in word register (Modbus)

5.10.1 Type – Word register

1.1.1 KNX Modbus RTU Gateway 886 > Datapoints 1 - 10	
Description	Slave address type <input checked="" type="radio"/> Common <input type="radio"/> For this page
General settings	Channel 1
Modbus settings	Datapoint type DPT 06 - signed - 1 byte
Datapoints 1 - 10	Description <input type="text"/>
Datapoints 11 - 20	Direction <input checked="" type="radio"/> KNX to modbus <input type="radio"/> Modbus to KNX
Datapoints 21 - 30	Type Word register
Datapoints 31 - 40	Position (register) Configured
Datapoints 41 - 50	Offset 00 bit
Datapoints 51 - 60	Function Write single holding register - 06
	Address 0

Position (register)

This parameter defines the area of the word register which is read/written. The following areas are available:

- Low byte
- High byte
- Configured

Offset (only for configured)

This parameter defines the position of the area in the word register (offset from the right in bits).

5.11 Channel function “DPT 07 – configured – 2 bytes”

Type

The following types are configurable:

- Bit register
2 byte value configured (KNX) sets bit register (Modbus)
- Bit in word register
2 byte value configured (KNX) sets 1 bit in word register (Modbus)
- Value in word register
2 byte value configured (KNX) is mapped to value in word register (Modbus)

5.11.1 Type – Bit register

5.11.1.1 Direction – KNX to Modbus

1.1.1 KNX Modbus RTU Gateway 886 > Datapoints 1 - 10	
Description	Slave address type <input checked="" type="radio"/> Common <input type="radio"/> For this page
General settings	Channel 1
Modbus settings	Datapoint type DPT 07 - configured - 2 bytes ▾
Datapoints 1 - 10	Description <input type="text"/>
Datapoints 11 - 20	Direction <input checked="" type="radio"/> KNX to modbus <input type="radio"/> Modbus to KNX
Datapoints 21 - 30	Type Bit register ▾
Datapoints 31 - 40	Value (object) 65535 ▾
Datapoints 41 - 50	Behaviour on value higher Register '0' ▾
Datapoints 51 - 60	Behaviour on value match Register '1' ▾
Datapoints 61 - 70	Behaviour on value lower Register '0' ▾
	Function Write single coil - 05
	Address 0 ▾

Value (object)

This parameter defines the value for which the group object (KNX) is checked.

Behaviour on value higher

This parameter defines the behaviour of the bit register in case the received value (KNX) is greater than the parameterized value. The following options are available:

- No reaction
- Register '1'
- Register '0'

Behaviour on value match

This parameter defines the behaviour of the bit register in case the received value (KNX) corresponds to the parameterized value. The following options are available:

- No reaction
- Register '1'
- Register '0'

Behaviour on value lower

This parameter defines the behaviour of the bit register in case the received value (KNX) is smaller than the parameterized value. The following options are available:

- No reaction
- Register '1'
- Register '0'

5.11.1.2 Direction – Modbus to KNX

1.1.1 KNX Modbus RTU Gateway 886 > Datapoints 1 - 10	
Description	Slave address type <input checked="" type="radio"/> Common <input type="radio"/> For this page
General settings	Channel 1
Modbus settings	Datapoint type DPT 07 - configured - 2 bytes
Datapoints 1 - 10	Description
Datapoints 11 - 20	Direction <input type="radio"/> KNX to modbus <input checked="" type="radio"/> Modbus to KNX
Datapoints 21 - 30	Send condition On change
Datapoints 31 - 40	Type Bit register
Datapoints 41 - 50	Behaviour on register '1' <input type="radio"/> No reaction <input checked="" type="radio"/> Send value
Datapoints 51 - 60	Value (object) 65535
Datapoints 61 - 70	Behaviour on register '0' <input type="radio"/> No reaction <input checked="" type="radio"/> Send value
Datapoints 71 - 80	Value (object) 0
Datapoints 81 - 90	Function <input checked="" type="radio"/> Read coils - 01 <input type="radio"/> Read discrete inputs - 02
	Address 0
	Polling interval Every cycle

Behaviour on register '1'

This parameter defines the behaviour of the group object in case the register is set. The following options are available:

- No reaction
- Send value

Value (object)

The value that is sent to KNX when the register is set.

Behaviour with register '0'

This parameter defines the behaviour of the group object in case the register is not set. The following options are available:

- No reaction
- Send value

Value (object)

The value that is sent to KNX when the register is not set.

5.11.2 Type – Bit in word register

5.11.2.1 Direction – KNX to Modbus

1.1.1 KNX Modbus RTU Gateway 886 > Datapoints 1 - 10	
Description	Slave address type <input checked="" type="radio"/> Common <input type="radio"/> For this page
General settings	Channel 1
Modbus settings	Datapoint type <input type="text" value="DPT 07 - configured - 2 bytes"/>
Datapoints 1 - 10	Description <input type="text"/>
Datapoints 11 - 20	Direction <input checked="" type="radio"/> KNX to modbus <input type="radio"/> Modbus to KNX
Datapoints 21 - 30	Type <input type="text" value="Bit in word register"/>
Datapoints 31 - 40	Value (object) <input type="text" value="65535"/>
Datapoints 41 - 50	Position (register) <input type="text" value="Bit 00"/>
Datapoints 51 - 60	Behaviour on value higher <input type="text" value="Register '0'"/>
Datapoints 61 - 70	Behaviour on value match <input type="text" value="Register '1'"/>
Datapoints 71 - 80	Behaviour on value lower <input type="text" value="Register '0'"/>
	Function <input type="text" value="Write single holding register - 06"/>
	Address <input type="text" value="0"/>

Value (object)

This parameter defines the value for which the group object (KNX) is checked.

Position (register)

Defines the bit in the word register.

Behaviour on value higher

This parameter defines the behaviour of the bit in the word register in case the received value (KNX) is greater than the parameterized value. The following options are available:

- No reaction
- Register '1'
- Register '0'

Behaviour on value match

This parameter defines the behaviour of the bit in the word register in case the received value (KNX) corresponds to the parameterized value. The following options are available:

- No reaction
- Register '1'
- Register '0'

Behaviour on value lower

This parameter defines the behaviour of the bit in the word register in case the received value (KNX) is smaller than the parameterized value. The following options are available:

- No reaction
- Register '1'
- Register '0'

5.11.2.2 Direction – Modbus to KNX

1.1.1 KNX Modbus RTU Gateway 886 > Datapoints 1 - 10	
Description	Slave address type <input checked="" type="radio"/> Common <input type="radio"/> For this page
General settings	Channel 1
Modbus settings	Datapoint type <input type="text" value="DPT 07 - configured - 2 bytes"/>
Datapoints 1 - 10	Description <input type="text"/>
Datapoints 11 - 20	Direction <input type="radio"/> KNX to modbus <input checked="" type="radio"/> Modbus to KNX
Datapoints 21 - 30	Send condition <input type="text" value="On change"/>
Datapoints 31 - 40	Type <input type="text" value="Bit in word register"/>
Datapoints 41 - 50	Position (register) <input type="text" value="Bit 00"/>
Datapoints 51 - 60	Behaviour on register '1' <input type="radio"/> No reaction <input checked="" type="radio"/> Send value
Datapoints 61 - 70	Value (object) <input type="text" value="65535"/>
Datapoints 71 - 80	Behaviour on register '0' <input type="radio"/> No reaction <input checked="" type="radio"/> Send value
Datapoints 81 - 90	Value (object) <input type="text" value="0"/>
Datapoints 91 - 100	Function <input checked="" type="radio"/> Read holding registers - 03 <input type="radio"/> Read input registers - 04
	Address <input type="text" value="0"/>
	Polling interval <input type="text" value="Every cycle"/>

Position (register)

Defines the bit in the word register.

Behaviour on register '1'

This parameter defines the behaviour of the group object in case the bit in the word register is set. The following options are available:

- No reaction
- Send value

Value (object)

The value that is sent to KNX when the bit in the word register is set.

Behaviour with register '0'

This parameter defines the behaviour of the group object in case the bit in the word register is not set. The following options are available:

- No reaction
- Send value

Value (object)

The value which is sent to KNX if the bit in the word register is not set.

5.11.3 Type – Value in word register

Bit count

This parameter defines the size of the value in the word register (in bits).

Offset

This parameter defines the position of the value in the word register (offset from the right in bits).

5.11.3.1 Direction – KNX to Modbus

1.1.1 KNX Modbus RTU Gateway 886 > Datapoints 1 - 10	
Description	Slave address type <input checked="" type="radio"/> Common <input type="radio"/> For this page
General settings	Channel 1
Modbus settings	Datapoint type DPT 07 - configured - 2 bytes
Datapoints 1 - 10	Description
Datapoints 11 - 20	Direction <input checked="" type="radio"/> KNX to modbus <input type="radio"/> Modbus to KNX
Datapoints 21 - 30	Type Value in word register
Datapoints 31 - 40	Value (object) 65535
Datapoints 41 - 50	Bit count 16 bit
Datapoints 51 - 60	Offset 00 bit
Datapoints 61 - 70	Behaviour on value higher <input type="radio"/> No reaction <input checked="" type="radio"/> Set register value
Datapoints 71 - 80	Value (register) 0
Datapoints 81 - 90	Behaviour on value match <input type="radio"/> No reaction <input checked="" type="radio"/> Set register value
Datapoints 91 - 100	Value (register) 1
Datapoints 101 - 110	Behaviour on value lower <input type="radio"/> No reaction <input checked="" type="radio"/> Set register value
	Value (register) 0
	Function Write single holding register - 06
	Address 0

Value (object)

This parameter defines the value for which the group object (KNX) is checked.

Behaviour on value higher

This parameter defines the behaviour of the word register in case the received value (KNX) is greater than the parameterized value. The following options are available:

- No reaction
- Set value in register

Value (register)

The value that is set in the word register.

Behaviour on value match

This parameter defines the behaviour of the word register in case the received value (KNX) corresponds to the parameterized value. The following options are available:

- No reaction
- Set value in register

Value (register)

The value that is set in the word register.

Behaviour on value lower

This parameter defines the behaviour of the word register in case the received value (KNX) is smaller than the parameterized value. The following options are available:

- No reaction
- Set value in register

Value (register)

The value that is set in the word register.

5.11.3.2 Direction – Modbus to KNX

1.1.1 KNX Modbus RTU Gateway 886 > Datapoints 1 - 10	
Description	Slave address type <input checked="" type="radio"/> Common <input type="radio"/> For this page
General settings	Channel 1
Modbus settings	Datapoint type <input type="text" value="DPT 07 - configured - 2 bytes"/>
Datapoints 1 - 10	Description <input type="text"/>
Datapoints 11 - 20	Direction <input type="radio"/> KNX to modbus <input checked="" type="radio"/> Modbus to KNX
Datapoints 21 - 30	Send condition <input type="text" value="On change"/>
Datapoints 31 - 40	Type <input type="text" value="Value in word register"/>
Datapoints 41 - 50	Bit count <input type="text" value="16 bit"/>
Datapoints 51 - 60	Offset <input type="text" value="00 bit"/>
Datapoints 61 - 70	Value (register) <input type="text" value="1"/>
Datapoints 71 - 80	Behaviour on value higher <input type="radio"/> No reaction <input checked="" type="radio"/> Send value
Datapoints 81 - 90	Value (object) <input type="text" value="0"/>
Datapoints 91 - 100	Behaviour on value match <input type="radio"/> No reaction <input checked="" type="radio"/> Send value
Datapoints 101 - 110	Value (object) <input type="text" value="65535"/>
Datapoints 111 - 120	Behaviour on value lower <input type="radio"/> No reaction <input checked="" type="radio"/> Send value
Datapoints 121 - 130	Value (object) <input type="text" value="0"/>
Datapoints 131 - 140	Function <input checked="" type="radio"/> Read holding registers - 03 <input type="radio"/> Read input registers - 04
	Address <input type="text" value="0"/>
	Polling interval <input type="text" value="Every cycle"/>

Value (register)

This parameter defines the value for which the word register is checked.

Behaviour on value higher

This parameter defines the behaviour of the group object (KNX) in the event that the register value is greater than the parameterized value. The following options are available:

- No reaction
- Send value

Value (object)

The value that is sent via the group object (KNX).

Behaviour on value match

This parameter defines the behaviour of the group object (KNX) in the event that the register value corresponds to the parameterized value. The following options are available:

- No reaction
- Send value

Value (object)

The value that is sent via the group object (KNX).

Behaviour on value lower

This parameter defines the behaviour of the group object (KNX) in the event that the register value is smaller than the parameterized value. The following options are available:

- No reaction
- Send value

Value (object)

The value that is sent via the group object (KNX).

5.12 Channel function “DPT 07 – unsigned – 2 bytes”

Type

The following type is configured:

- Word register
2 byte value unsigned (KNX) is written/read to/from area in word register (Modbus)

5.12.1 Type – Word register

1.1.1 KNX Modbus RTU Gateway 886 > Datapoints 1 - 10	
Description	Slave address type <input checked="" type="radio"/> Common <input type="radio"/> For this page
General settings	Channel 1
Modbus settings	Datapoint type DPT 07 - unsigned - 2 bytes
Datapoints 1 - 10	Description <input type="text"/>
Datapoints 11 - 20	Direction <input checked="" type="radio"/> KNX to modbus <input type="radio"/> Modbus to KNX
Datapoints 21 - 30	Type Word register
Datapoints 31 - 40	Position (register) <input type="radio"/> High/Low byte <input checked="" type="radio"/> Configured
Datapoints 41 - 50	Bit count 16 bit
Datapoints 51 - 60	Offset 00 bit
	Function Write single holding register - 06
	Address 0

Position (register)

This parameter defines the area of the word register which is read/written. The following areas are available:

- High/Low byte
- Configured

Bit count (only for configured)

This parameter defines the size of the area in the word register (in bits).

Offset (only for configured)

This parameter defines the position of the area in the word register (offset from the right in bits).



The **Bit count** and **Offset** together must not be greater than 16.
The value must fit into **Bit count**, for example **Bit count** = 1 → “Value” = 0 or 1.

5.13 Channel function “DPT 08 – signed – 2 bytes”

Type

The following type is configured:

- Word register
2 byte value signed (KNX) is written/read to/from area in word register (Modbus)

5.13.1 Type – Word register

1.1.1 KNX Modbus RTU Gateway 886 > Datapoints 1 - 10	
Description	Slave address type <input checked="" type="radio"/> Common <input type="radio"/> For this page
General settings	Channel 1
Modbus settings	Datapoint type DPT 08 - signed - 2 bytes
Datapoints 1 - 10	Description <input type="text"/>
Datapoints 11 - 20	Direction <input checked="" type="radio"/> KNX to modbus <input type="radio"/> Modbus to KNX
Datapoints 21 - 30	Type Word register
Datapoints 31 - 40	Position (register) High/Low byte
Datapoints 41 - 50	Function Write single holding register - 06
	Address 0

Position (register)

This parameter defines the area of the word register which is read/written. The following area is configured:

- High/Low byte

5.14 Channel Function “DPT 09 – float – 2 bytes”

Type

The following type is configured:

- Word register
2 byte float value (KNX) is mapped to area in word register (Modbus)

5.14.1 Type – Word register

1.1.1 KNX Modbus RTU Gateway 886 > Datapoints 1 - 10	
Description	Slave address type <input checked="" type="radio"/> Common <input type="radio"/> For this page
General settings	Channel 1
Modbus settings	Datapoint type DPT 09 - float - 2 bytes
Datapoints 1 - 10	Description <input type="text"/>
Datapoints 11 - 20	Direction <input type="radio"/> KNX to modbus <input checked="" type="radio"/> Modbus to KNX
Datapoints 21 - 30	Send condition On change
Datapoints 31 - 40	Value change <input type="text" value="0.5"/>
Datapoints 41 - 50	Type Word register
Datapoints 51 - 60	Position (register) High/Low byte - unsigned
Datapoints 61 - 70	Value minimum (register) <input type="text" value="0"/>
Datapoints 71 - 80	Value maximum (register) <input type="text" value="100"/>
Datapoints 81 - 90	Value minimum (KNX) <input type="text" value="0"/>
Datapoints 91 - 100	Value maximum (KNX) <input type="text" value="100"/>
Datapoints 101 - 110	Function <input checked="" type="radio"/> Read holding registers - 03 <input type="radio"/> Read input registers - 04
	Address <input type="text" value="0"/>
	Polling interval Every cycle

Position (register)

This parameter defines the area of the word register that is mapped. The following areas are available:

- Low byte – unsigned
- High byte – unsigned
- High/Low byte – unsigned
- Low byte – 2th complement
- High byte – 2th complement
- High/Low byte – 2th complement

Value minimum (register)

Register value which corresponds to **Value minimum (KNX)**.

Value maximum (register)

Register value which corresponds to **Value maximum (KNX)**.

Value minimum (KNX)

KNX value which corresponds to **Value minimum (register)**.

Value maximum (KNX)

KNX value, which corresponds to **Value maximum (register)**.



*The conversion is always transferred to the entire register area.
Value minimum/maximum (register) defines no limits.*

5.15 Channel Function “DPT 14 – float – 4 bytes”

Type

The following types are configurable:

- Word register
4 byte float value (KNX) is mapped to area in word register (Modbus)
- Double word register
4 byte float value (KNX) is mapped to two word registers (Modbus)

5.15.1 Type – Word register

1.1.1 KNX Modbus RTU Gateway 886 > Datapoints 1 - 10	
Description	Slave address type <input checked="" type="radio"/> Common <input type="radio"/> For this page
General settings	Channel 1
Modbus settings	Datapoint type ▼ DPT 14 - float - 4 bytes
Datapoints 1 - 10	Description <input type="text"/>
Datapoints 11 - 20	Direction <input type="radio"/> KNX to modbus <input checked="" type="radio"/> Modbus to KNX
Datapoints 21 - 30	Send condition ▼ On change
Datapoints 31 - 40	Value change <input type="text"/> 0.5
Datapoints 41 - 50	Type <input checked="" type="radio"/> Word register <input type="radio"/> Double word register
Datapoints 51 - 60	Position (register) ▼ High/Low byte - unsigned
Datapoints 61 - 70	Value minimum (register) <input type="text"/> 0
Datapoints 71 - 80	Value maximum (register) <input type="text"/> 100
Datapoints 81 - 90	Value minimum (KNX) <input type="text"/> 0
Datapoints 91 - 100	Value maximum (KNX) <input type="text"/> 100
Datapoints 101 - 110	Function <input checked="" type="radio"/> Read holding registers - 03 <input type="radio"/> Read input registers - 04
	Address <input type="text"/> 0
	Polling interval ▼ Every cycle

Position (register)

This parameter defines the area of the word register that is mapped. The following areas are available:

- Low byte – unsigned
- High byte – unsigned
- High/Low byte – unsigned
- Low byte – 2th complement
- High byte – 2th complement
- High/Low byte – 2th complement

Value minimum (register)

Register value which corresponds to **Value minimum (KNX)**.

Value maximum (register)

Register value which corresponds to **Value maximum (KNX)**.

Value minimum (KNX)

KNX value which corresponds to **Value minimum (register)**.

Value maximum (KNX)

KNX value, which corresponds to **Value maximum (register)**.



*The conversion is always transferred to the entire register area.
Value minimum/maximum (register) defines no limits.*

5.15.2 Type – Double word register

1.1.1 KNX Modbus RTU Gateway 886 > Datapoints 1 - 10	
Description	Slave address type <input checked="" type="radio"/> Common <input type="radio"/> For this page
General settings	Channel 1
Modbus settings	Datapoint type ▼ DPT 14 - float - 4 bytes
Datapoints 1 - 10	Description
Datapoints 11 - 20	Direction <input type="radio"/> KNX to modbus <input checked="" type="radio"/> Modbus to KNX
Datapoints 21 - 30	Send condition ▼ On change
Datapoints 31 - 40	Value change 0.5
Datapoints 41 - 50	Type <input type="radio"/> Word register <input checked="" type="radio"/> Double word register
Datapoints 51 - 60	Word order <input checked="" type="radio"/> Hi word @ address / Lo word @ address + 1 <input type="radio"/> Lo word @ address / Hi word @ address + 1
Datapoints 61 - 70	Type register value ▼ Modbus holds integer value - unsigned
Datapoints 71 - 80	Value minimum (register) ▲▼ 0
Datapoints 81 - 90	Value maximum (register) ▲▼ 100
Datapoints 91 - 100	Value minimum (KNX) 0
Datapoints 101 - 110	Value maximum (KNX) 100
Datapoints 111 - 120	Function <input checked="" type="radio"/> Read holding registers - 03 <input type="radio"/> Read input registers - 04
	Address ▲▼ 0
	Polling interval ▼ Every cycle

Word order

This parameter defines the byte order in which the value of the group object (KNX) is distributed to the two word registers (Modbus). The following options are available:

- Hi word @ Address / Lo word @ Address + 1
- Lo word @ Address / Hi word @ Address + 1

Type Register value

This parameter defines how the float value is mapped to Modbus. The following options are available:

- Modbus contains integer value – unsigned
- Modbus contains integer value – 2th complement
- Modbus contains float value (IEEE)

Value minimum (register)

Register value which corresponds to **Value minimum (KNX)**.

Value maximum (register)

Register value which corresponds to **Value maximum (KNX)**.

Value minimum (KNX)

KNX value which corresponds to **Value minimum (register)**.

Value maximum (KNX)

KNX value, which corresponds to **Value maximum (register)**.



*The conversion is always transferred to the entire register area.
Value minimum/maximum (register) defines no limits.*

Function (for “KNX to Modbus” and “Double word register”)

This parameter defines the transmission mode of the double word register. The following options are available:

- Write multi holding registers – 16
Both word registers in one request
- Write single holding register – 06
For each word register one request



As “Modbus master”, with “Modbus to KNX” and “Double word register”, multi read requests should be activated in order to read both word registers in one request.

Address (for “Double word register”)

Double word registers use the register address specified here as well as this register address + 1.

5.16 General information

5.16.1 Scaling

The scaling factor can be defined with the respective minimum/maximum values.

Example:

Value minimum (register) = 0

Value maximum (register) = 100

Value minimum (KNX) = 0

Value maximum (KNX) = 10

The result is scaling * 10 of the KNX value:

Value KNX = 10.5 → Value Register = 105



*The conversion is always transferred to the entire register area.
Value minimum/maximum (register) defines no limits.*

5.16.2 2th complement

The 2th complement is used in Modbus registers to represent negative values. Thus, for example, a range of -32768...32767 can be displayed on a word register.

5.16.3 Modbus communication

If the KNX Gateway (master mode) does not receive a response from the slave within 1 second, the request is repeated twice. If these are not successful, all channels of this parameter page are skipped.

If the slave takes longer than 1 second to process the data, it can send an acknowledge telegram which restarts the time interval at the master.



WARNING

- The device must be mounted and commissioned by an authorized electrician.
- The prevailing safety rules must be heeded.
- The device must not be opened.
- For planning and construction of electric installations, the relevant guidelines, regulations and standards of the respective country are to be considered.

ETS5 Database

www.weinzierl.de/en/products/886/ets5

Data sheet

www.weinzierl.de/en/products/886/datasheet

CE Declaration

www.weinzierl.de/en/products/886/ce-declaration



Weinzierl Engineering GmbH

Achatz 3

DE-84508 Burgkirchen / Alz
GERMANY

Tel: +49 (0)8677 / 91 636 – 0
info@weinzierl.de
www.weinzierl.de

2021-05-26