

Intra-Sewi KNX L-Pr and Intra-Sewi KNX TH-L-Pr Brightness and Presence Detectors

Technical specifications and installation instructions

Item numbers

- 70671 Intra-Sewi KNX L-Pr, white
- 70672 Intra-Sewi KNX L-Pr, black
- 70681 Intra-Sewi KNX TH-L-Pr, white
- 70682 Intra-Sewi KNX TH-L-Pr, black

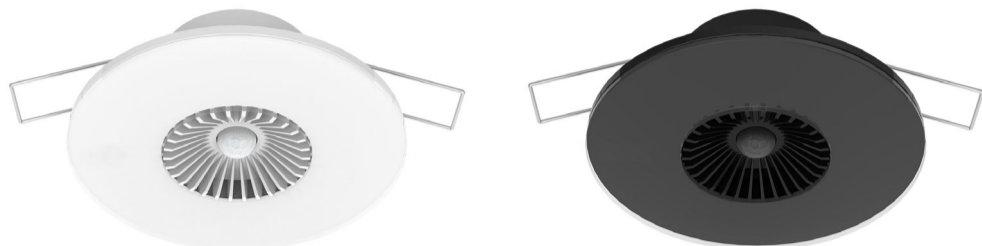

1. Description

The **Sensor Intra-Sewi KNX L-Pr** for the KNX building bus system captures brightness and the presence of persons in rooms.

The **Sensor Intra-Sewi KNX TH-L-Pr** additionally measures the temperature and the air humidity and calculates the dew-point. Via the bus, the indoor sensor can receive external values of temperature and humidity and process them further with its own data to a total value (mixed value, e.g. room average). Integrated PI-controllers control ventilation (humidification/dehumidification according to humidity) and heating/cooling (according to temperature).

The **Sensor Intra-Sewi KNX TH-L-Pr** can output a warning to the bus as soon as the comfort field, as per DIN 1946, is left. Actuating variable comparators can compare and output variables that were received via communication objects.

All measurement values can be used for the control of limit-dependent switching outputs. States can be linked via AND logic gates and OR logic gates.

Functions:

- **Brightness measurement with brightness control**
- **Presence of persons is detected**
- **Threshold values** can be adjusted per parameter or via communication objects
- **4 AND and 4 OR logic gates**, each with 4 inputs. All switching events as well as 16 logic inputs (in the form of communications objects) can be used as inputs for the logic gates. The output of each gate can be configured optionally as 1-bit or 2 x 8-bit

Additional functions Intra-Sewi KNX TH-L-Pr:

- Measuring the **temperature** and **air humidity** (relative, absolute), each with **mixed value calculation**. The share of internal measurement value and external value can be set as a percentage
- Bus message, whether the values for temperature and air humidity are within the **comfort field** (DIN 1946). **Dew point** calculation
- **PI-controller for heating** (one or two-stage) and **cooling** (one or two-stage) according to temperature. Regulation according to separate setpoints or basic setpoint temperature
- **PI controller for humidity** according to humidity: Ventilate/Air (one-stage) or Ventilate (one or two-stage)
- **2 actuation variable comparators** to output minimum, maximum or average values. 5 inputs each for values received via communication objects

Configuration is made using the KNX software ETS. The **product file** can be downloaded from the Elsner Elektronik website on www.elsner-elektronik.de in the "Service" menu.

1.0.1. Scope of delivery

- Sensor
- Pre-assembled clamps for false ceiling installation
- Support ring for connector socket installation

For socket installation you will need *in addition* (not supplied):

- Socket Ø 60 mm, 42 mm deep

1.1. Technical data

General:	
Housing	Plastic, glass
Colour	<ul style="list-style-type: none"> • similar to pure white RAL 9010 • similar to jet black RAL 9005
Assembly	built-in, in false ceiling or connector socket
Dimensions Ø x height above wall	approx. 80 mm x approx. 5 mm height in wall (installation) approx. 31 mm (incl. clamps)
Degree of protection	IP 30
Weight	approx. 50 g
Ambient temperature	-20...+60°C
Ambient humidity	5...95% RH, non-condensing
Storage temperature	-30...+70°C
KNX bus:	

KNX medium	TP1-256
Configuration mode	S-Mode
Group addresses	max. 254
Assignments	max. 254
Communication objects	Intra-Sewi KNX TH-L-Pr: 252 Intra-Sewi KNX L-Pr: 122
Nominal voltage KNX	30 V SELV
Power consumption KNX	max. 10 mA
Connection	KNX plug terminals
Duration after bus voltage restoration until data is received	approx. 5 seconds

Sensors:

Brightness sensor:

Measurement range	0 lux ... 2,000 lux (higher values can be measured and output)
Resolution	1 lux at 0...2,000 lux

Presence sensor:

Detection method	Passive infrared method (PIR)
Coverage angle	approx. 94° x 82° (see also <i>Coverage area of the presence detector</i>)
Range	approx. 5 m

Temperature sensor (only Intra-Sewi KNX TH-L-Pr):

Measurement range	-20°C ... +60°C
Resolution	0.1°C

Humidity sensor (only Intra-Sewi KNX TH-L-Pr):

Measurement range	0% rH ... 100% rH
Resolution	0.1% rH

The product is compliant with the provisions of the EU guidelines.

1.1.1. Measuring accuracy

Deviations in measured values due to interfering sources (see chapter *installation location*) must be corrected in the ETS in order to achieve the specified accuracy of the sensor (offset).

During the **Temperature measurement**, the self-heating of the device is taken into consideration by the electronics. It is compensated by the software, therefore the displayed/output indoor temperature measuring value is correct.

2. Safety and use instructions



Installation, testing, operational start-up and troubleshooting should only be performed by an authorised electrician.



CAUTION! Live voltage!

There are unprotected live components inside the device.

- Inspect the device for damage before installation. Only put undamaged devices into operation.
- Comply with the locally applicable directives, regulations and provisions for electrical installation.
- Immediately take the device or system out of service and secure it against unintentional switch-on if risk-free operation is no longer guaranteed.

Use the device exclusively for building automation and observe the operating instructions. Improper use, modifications to the device or failure to observe the operating instructions will invalidate any warranty or guarantee claims.

Operate the device only as a fixed-site installation, i.e. only in assembled condition and after conclusion of all installation and operational start-up tasks, and only in the surroundings designated for it.

Elsner Elektronik is not liable for any changes in norms and standards which may occur after publication of these operating instructions.

3. Installation

3.1. Installation location and preparation



Install and use only in dry interior rooms! Avoid condensation.

The Sensor is installed in a false ceiling or a standard connection socket (Ø 60 mm, 42 mm deep).

The device must be installed on the ceiling, so that the **presence of people is detected** from above. Make sure that the desired area is covered by the sensor's coverage angle and that no obstacles obstruct the recording.

When selecting an installation location for **Intra-Sewi KNX TH-L-Pr**, please ensure that the measurement results of **temperature and humidity** are affected as little as possible by external influences. Possible sources of interference include:

- Direct sunlight
- Drafts from windows and doors
- Draughts from ducts coming from other rooms or the outdoors
- Warming or cooling of the building structure on which the sensor is mounted, e.g. due to sunlight, heating or cold water pipes
- Connection lines and empty ducts which lead from warmer or colder areas to the sensor

Measurement variations from such sources of interference must be corrected in the ETS in order to ensure the specified accuracy of the sensor (offset).

3.1.1. Coverage area of the presence detector

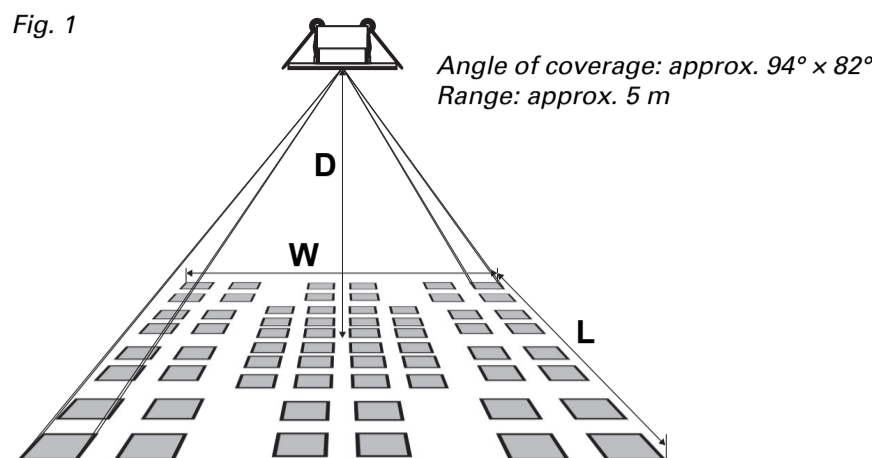

Distance D	Length L	Width W
2.50 m	approx. 5.40 m	approx. 4.30 m
3.50 m	approx. 7.50 m	approx. 6.10 m

3.2. Connection

⚡ For installation and wiring at the KNX connection, the provisions and standards applicable to SELV circuits must be complied with!

The connection is made with the KNX terminal (red/black) to KNX TP.

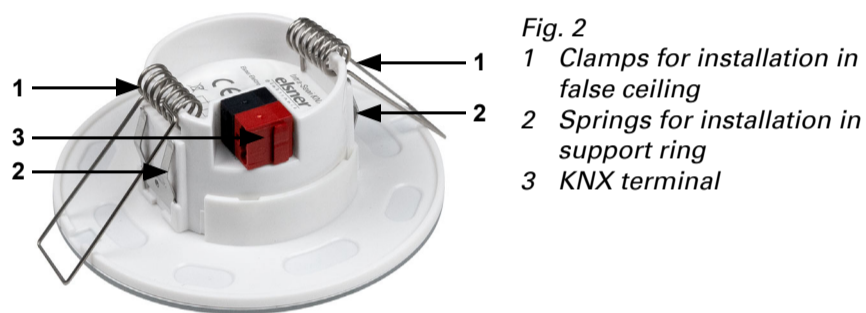

Fig. 2
1 Clamps for installation in false ceiling
2 Springs for installation in support ring
3 KNX terminal

3.2.1. Assembly

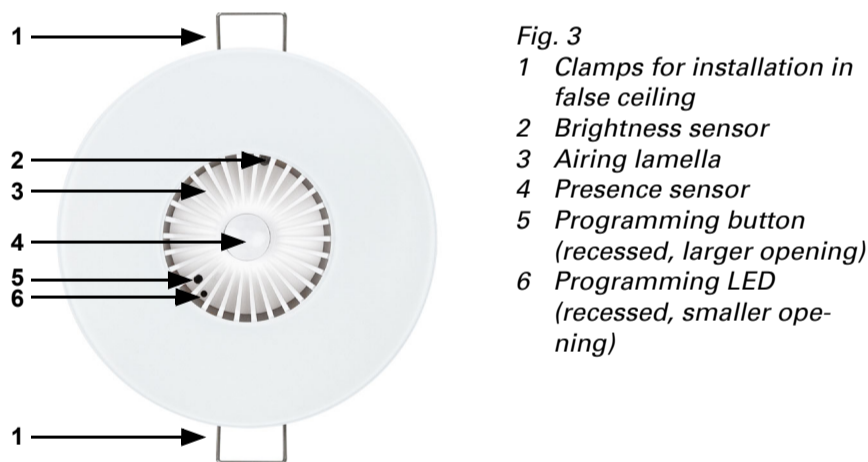

Fig. 3
1 Clamps for installation in false ceiling
2 Brightness sensor
3 Airing lamella
4 Presence sensor
5 Programming button (recessed, larger opening)
6 Programming LED (recessed, smaller opening)

Installation in false ceiling

Connect the bus line to the KNX terminal (red/black).

Place the device in the installation opening in the ceiling. For this, fold the clamps upwards and guide the device through the installation opening with the clamps first.

The device is automatically fixed by the clamps.

Fig. 4
1 Clamps for installation in false ceiling
A Height in wall (built-in): approx. 31 mm
B Space behind the false ceiling, necessary for insertion (clear dimension): approx. 31 mm
C Maximum wall thickness: 20 mm
D Hole size for installation: 50...65 mm

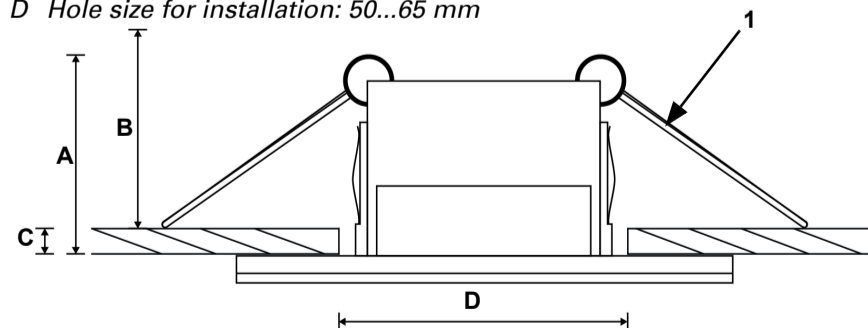

Installation in connector socket

Before socket installation, remove the clamps for the false ceiling installation.

Screw the support ring onto the socket. Pay attention to the orientation as shown in the chapter *Coverage area of the presence detector*.

Connect the bus line to the KNX terminal (red/black).

Clamp the device in the support ring so that the springs on the device snap over the tabs of the support ring.

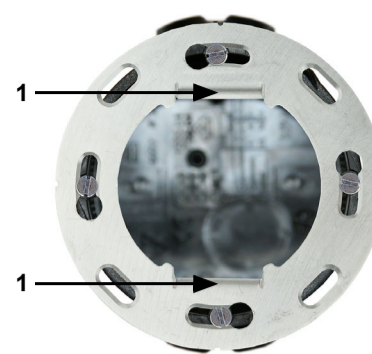
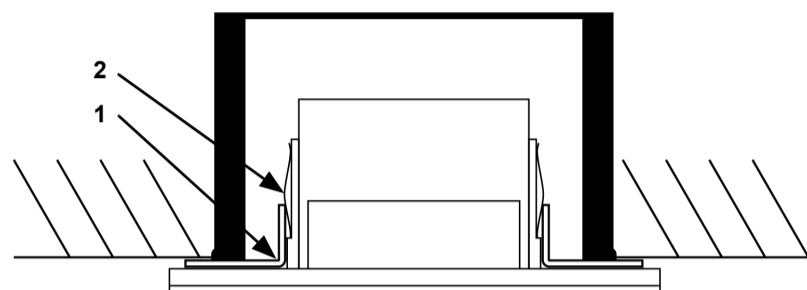

Fig. 5: Tragrung
1 Tabs

Fig. 6
Connector socket with Ø 60 mm, 42 mm deep.
1 Support ring, screwed to the socket
2 Springs hold the device firmly on the support ring



4. Commissioning

Brightness sensor, presence sensor and ventilation slots on the side must not be dirty, painted over or covered.

After the bus voltage has been applied, the device will enter an initialisation phase lasting approx. 5 seconds. During this phase no information can be received or sent via the bus.

The presence sensor has a start-up phase of approx. 15 seconds during which the presence of persons is not detected.

4.1. Addressing the equipment

The individual address is assigned via the ETS. For this purpose there is a button with a control LED on the unit (Fig. 3, No. 5+6).

The equipment is delivered with the bus address 15.15.255. Another address can be programmed using the ETS.

5. Maintenance

As a rule, it is sufficient to wipe the device with a soft, dry cloth twice a year.

6. Disposal

After use, the device must be disposed of in accordance with the legal regulations. Do not dispose of it with the household waste!