

KNX K4 Actuator for heating and cooling

Technical specifications and installation instructions

Item number 70320

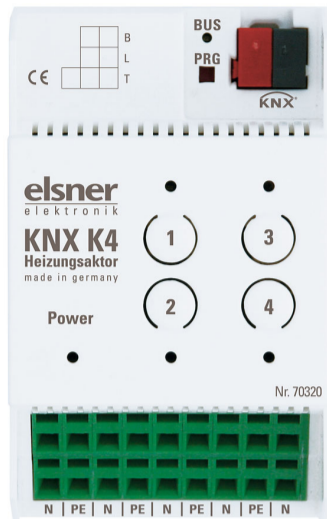

1. Description

The **KNX K4 actuator** offers four internal temperature regulators and four output channels for controlling heating or cooling systems. The temperature regulators can control both the outputs on the **KNX K4** and other climate control system on the KNX-Bus.

In automatic mode, the temperature regulators are set at nominal temperatures for different modes. This way, it is easy to switch between the modes, comfort, standby, eco and building protection. The switch is made via an object e. g. via a manual switch, time switch or sensor switch outputs in the KNX-System.

The buttons on the device allow for direct manual switching of the connected systems. LEDs show whether the output channel was manually operated or is running in an automatic mode.

Functions:

- **4 internal, independent temperature regulators** with automatic controls for the **heating and cooling controls** (one/two step heating and cooling)
- **4 output channels** (230 V AC, 8 Watt per output) with pulse width modulation control (PWM) for actuators
- Keypad field **4 buttons** and status LEDs

Configuration is made using the KNX software ETS. The **product file** can be downloaded from the Elsner Elektronik website on www.elsner-elektronik.de in the "Service" menu.

1.1. Technical data

| | |
|-----------------------|---|
| Housing | Plastic |
| Colour | White |
| Mounting | Series installation on mounting rail |
| Protection category | IP 20 |
| Dimensions | approx. 53 x 88 x 60 (W x H x D, mm), 3 modules |
| Weight | approx. 110 g |
| Ambient temperature | Operation -20...+45°C, storage -55...+90°C |
| Ambient humidity | max. 95% RH, avoid condensation |
| Operating voltage | KNX bus voltage |
| Power | on bus: 10 mA |
| Outputs | 4 x 230 V (OUT/N), not short-circuit-proof. When connecting one consumer load per separate channel (1 to 4): Max. load for continuous operation: 8 W per channel Max. switch-on current: 1.1 A per channel Observe the specifications in the data sheet of the consumer load. |
| Maximum load | Each terminal contact may be loaded with a maximum of 10 A. |
| Data output | KNX +/- bus connector terminal |
| BCU type | unit's own microcontroller |
| PEI type | 0 |
| Group addresses | max. 254 |
| Assignments | max. 254 |
| Communication objects | 125 |

The product conforms with the provisions of EU directives.

2. Installation and start-up

2.1. Installation notes



Installation, testing, operational start-up and troubleshooting should only be performed by an electrician.



DANGER!

Risk to life from live voltage (mains voltage)!

There are unprotected live components within the device.

- VDE regulations and national regulations are to be followed.
- Ensure that all lines to be assembled are free of voltage and take precautions against accidental switching on.
- Do not use the device if it is damaged.
- Take the device or system out of service and secure it against unintentional use, if it can be assumed, that risk-free operation is no longer guaranteed.

The device is only to be used for the intended purpose described in this manual. Any improper modification or failure to follow the operating instructions voids any and all warranty and guarantee claims.

After unpacking the device, check it immediately for possible mechanical damage. If it has been damaged in transport, inform the supplier immediately.

The device may only be used as a fixed-site installation; that means only when assembled and after conclusion of all installation and operational start-up tasks and only in the surroundings designated for it.

Elsner Elektronik is not liable for any changes in norms and standards which may occur after publication of these operating instructions.

2.2. Safety notice for automatic functions



WARNING!

Risk of injury from automatically moving components!

Parts of the system can be started by the automatic controls and be a danger to persons.

- No persons may remain in the travelling range of parts driven by an electric motor.
- Adhere to the relevant building regulations.
- Ensure that the return path/access to the building is not blocked if spending time outside the building (danger of being locked out).
- Correctly decommission the system for maintenance and cleaning work.

If there is a power outage, the system does not work. Therefore, shadings should be moved to a save position if there are anticipated weather conditions, for example, if this has not already been done by the automatic function (product protection).

If the power supply is removed, the connected drive switches off. When the power is restored, the consumer remains switched off until a new movement command is received by the actuator.

2.3. Device connection and design

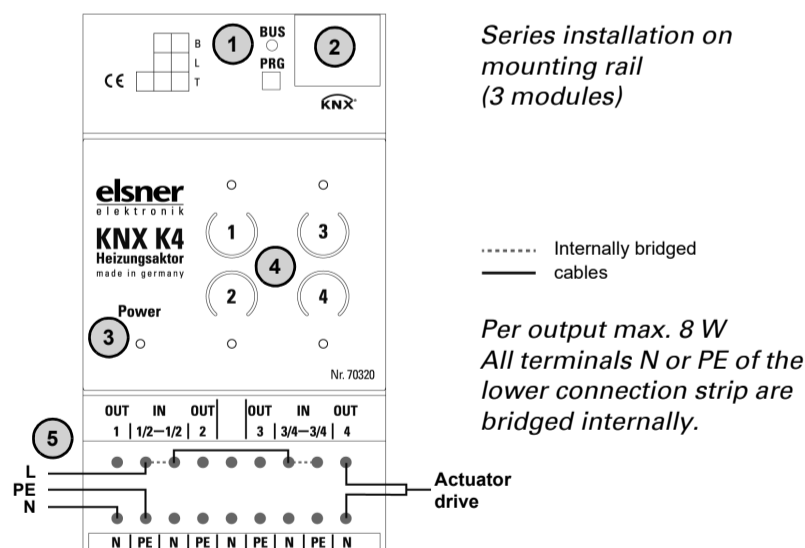

- 1) Programming LED and programming buttons (PRG)
- 2) Bus terminal slot (KNX +/-)
- 3) Power LED (supply voltage/Bus)
- 4) Buttons and LEDs outputs 1-4
- 5) **Sample connection:** L (230 V) was bridged in this example from IN 1/2 to IN 3/4.
Actuator on output 4 (OUT 4 | N)
Each terminal contact may be loaded with a maximum of 10 A.

2.4. Notes on mounting and commissioning

Device must not be exposed to water (rain). This could result in the electronics being damaged. A relative air humidity of 95% must not be exceeded. Avoid condensation.

After the operating voltage has been applied, the device will enter an initialisation phase lasting a few seconds. During this phase no information can be received or sent via the bus.

2.4.1. Buttons and LEDs for the output channels

The buttons on the devices can be deactivated in the ETS (active when delivered).

Buttons

| | |
|-----------------------------|--|
| brief button press (<0,5 s) | LED shows current status (see ETS parameter: Channel LED) |
| button press >0,5 s | <i>in Automatic mode:</i> Switching to Manual mode <i>in Manal mode:</i> Switching from manually ON to manually OFF and reverse |
| long button press (>3 s) | Switching to Automatic mode (when activated in ETS) |

LEDs

Behaviour of the LEDs for the output channels in Automatic mode:

| | |
|-----|-------------------------|
| Off | Actuating variable = 0% |
| On | Actuating variable > 0% |

in Manual mode:

| | |
|----------------|--------------|
| Flashes slowly | Manually OFF |
| Flashes fast | Manually ON |

3. Addressing of the device at the bus

The device is supplied with the bus address 15.15.255. You can program another address into the ETS by overwriting the 15.15.255 address or by teaching via the programming button.

4. Disposal

After use, the device must be disposed of or recycled in accordance with the legal regulations. Do not dispose of it with the household waste!